

Control Valve

# BOA-CVE H

PN 16/25  
DN 20-150

## Type Series Booklet



## **Legal information/Copyright**

Type Series Booklet BOA-CVE H

KSB Aktiengesellschaft Pegnitz

All rights reserved. Contents provided herein must neither be distributed, copied, reproduced, edited or processed for any other purpose, nor otherwise transmitted, published or made available to a third party without KSB's express written consent.

Subject to technical modification without prior notice.

© KSB Aktiengesellschaft Frankenthal

## Balancing and Measurement Valves

### Control Valves

## BOA-CVE H



### Main applications

- Hot-water heating systems
- Air-conditioning systems
- Boiler feed applications
- Boiler recirculation
- Chemical industry
- Process engineering
- Heat recovery systems
- Sugar industry

### Fluids handled

- High-temperature hot water
- Saturated steam
- Liquids not chemically or mechanically aggressive to the valve materials.

### Operating data

Operating properties

Characteristic	Value
Nominal pressure	PN 16/25
Nominal size	DN 20-150
Max. permissible pressure	25 bar
Max. permissible temperature	350 °C

Selection as per pressure/temperature ratings (⇒ Page 4)

### Design details

#### Design

Control valve:

- Straight-way pattern with horizontal seat
- $k_{vs}$  values: 2.5 to 340 m<sup>3</sup>/h
- Rangeability 50:1
- Parabolic plug with equal-percentage or linear characteristic
- Two-stage pressure reduction (parabolic plug combined with multi-hole cage)
- Reduced  $k_{vs}$  values
- PTFE V-rings with spring up to 250 °C
- Graphite gland packing up to 350 °C
- Flanges to DIN EN 1092-2 Type 21
- Leakage class IV (DIN EN 60534-4)
- The valves satisfy the safety requirements of Annex I of the European Pressure Equipment Directive 97/23/EC (PED) for fluids in Groups 1 and 2.

Actuators (technical data refers to basic configuration):

- Configurable, microprocessor-controlled actuators  
Supply voltage: 24 V AC / 230 V AC  
Position setpoint: 4 - 20 mA  
Actual-position feedback value: 4 - 20 mA
- 3-point (Open/Stop/Closed) actuators  
Supply voltage: 230 V AC  
Actual-position feedback value: 2 limit switches

### Variants

Control valve:

- Seat with PTFE gasket up to 250 °C, leakage class VI
- Anti-cavitation design
- Very low  $k_{vs}$  values from 0.1 to 2.1 m<sup>3</sup>/h
- Balanced plug from DN 65 (up to 200 °C)
- Other flange designs
- High-temperature resistant paint (grey aluminium)
- Certification to customer specification

Actuators:

- Actuator configured to match the order specification
- Integrated process controller
- Power back-up unit
- Heating of the motor space

### Body materials

Overview of available materials

Material	Material number	Temperature limit
EN-GJS-400-18-LT	JS 1025	Up to 350 °C

### Product benefits

- Two-stage pressure reduction already integrated as a standard to reduce noise emission.
- Optional anti-cavitation design combines supporting cage and perforated plug.
- Easy to adjust to specific control tasks by selecting from various valve plug (equal-percentage or linear) / seat diameter combinations.
- Available with two types of stem seal: maintenance-free PTFE V-rings with spring (< 250 °C) or adjustable graphite gland packing (350 °C).

- Electric actuator with parameterisable actuation: continuous-action or 3-point; integration in a process control system via 0/2-10 V or 0/4-20 mA signal; available in various sizes up to 14 kN.
- Easy to service: The valve trim can be dismantled without any special tools by unscrewing the bonnet bolts.
- Internal parts made of high-grade stainless steel (1.4571) for long service life and high chemical resistance.
- Risk of leakage minimised by fully confined bonnet gasket.

**Related documents**

Other applicable documentation

Document	Reference No.
Flow characteristics	7525.4
BOA-CVE H operating manual	7525.81
Electric actuators, operating manual	7525.82

**Pressure/temperature ratings**

Test and operating pressures

Nominal pressure	Material	Body pressure test	Seat tightness test	Permissible operating pressures in bar at temperatures in °C <sup>1)2)</sup>				
				with water				
		P10, P11		-10 to +120	200	250	300	350
PN		[bar] <sup>3)</sup>	[bar] <sup>4)</sup>					
16	EN-GJS-400-18-LT	24	Δp	16	14.7	13.9	12.8	11.2
25	EN-GJS-400-18-LT	37.5	Δp	25	23	21.8	20	17.5

**Valve characteristics**

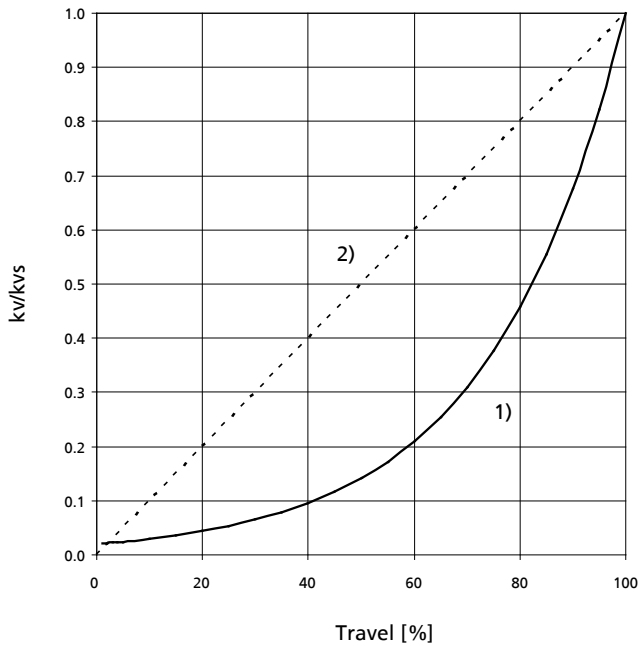

1)	equal-percentage	2)	linear
----	------------------	----	--------

1) Intermediate temperatures can be derived by linear interpolation.  
 2) Static load  
 3) DIN EN 12266-1 (P10, P11)  
 4) Test procedure 1 to DIN EN 60534-4

### Actuating times

Actuating times in s

Seat diameter [mm]	Travel [mm]	EA-C 20	EA-C 40	EA-C 80	EA-C 140
4	20	23 - 46 (40)			
8					
12					
15					
20					
25	32	36 - 72 (64)	36 - 72 (64)	54 - 108 (64)	25 - 50 (72)
32					
40					
50					
65					
80	45		50 - 100 (90)	75 - 150 (90)	35 - 70 (100)
100					
125					
150					

Standard actuating times for continuous-action actuators.  
Values for 3-point actuators in brackets.

### Possible combinations of nominal size and seat diameter

Possible combinations of nominal size and seat diameter

DN	Seat diameter [mm]													
	4	8	12	15	20	25	32	40	50	65	80	100	125	150
20	*	•	•	•	•									
25	*	•	•	•	•	•								
32	*	*	*	*	•	•	•							
40	*	*	*	*	*	•	•	•						
50	*	*	*	*	*	*	•	•	•					
65	*	*	*	*	*	*	*	•	•	•				
80	*	*	*	*	*	*	*	*	•	•	•			
100	*	*	*	*	*	*	*	*	*	•	•	•		
125	*	*	*	*	*	*	*	*	*	*	•	•	•	
150	*	*	*	*	*	*	*	*	*	*	*	•	•	•

Key to the symbols

Symbol	Description
•	Standard model
*	Available upon request.

**Maximum permissible closing pressures**

 Fluid approaches the valve disc in closing direction;  $p_2 = 0$  bar  
 Values in bar

Seat diameter [mm]	Travel [mm]	EA-C 20 (2 kN)		EA-C40 (4.5 kN)		EA-C80 (8 kN)		EAC-140 (14 kN)	
		Graphite gland packing	PTFE V-rings with spring	Graphite gland packing	PTFE V-rings with spring	Graphite gland packing	PTFE V-rings with spring	Graphite gland packing	PTFE V-rings with spring
4	20	25.0	25.0						
8		25	25						
12		25	25						
15		25	25						
20		25	25						
25		25	25						
32	32	14.8	20.2	25.0	25.0				
40		8.9	12.4	25.0	25.0				
50		5.3	7.6	18.1	20.3	25.0	25.0		
65		2.4	4.0	9.9	11.6	20.5	22.1	25.0	25.0
80		1.3	2.4	6.3	7.4	13.3	14.4	25.0	25.0
100			1.3	3.8	4.5	8.3	9.0	15.9	16.6
125	45			2.2	2.7	5.0	5.6	9.9	10.5
150						3.4	3.8	6.8	7.1

All values without balanced plug and based on leakage class IV

Flow characteristics

Equal-percentage characteristics, rangeability 50:1

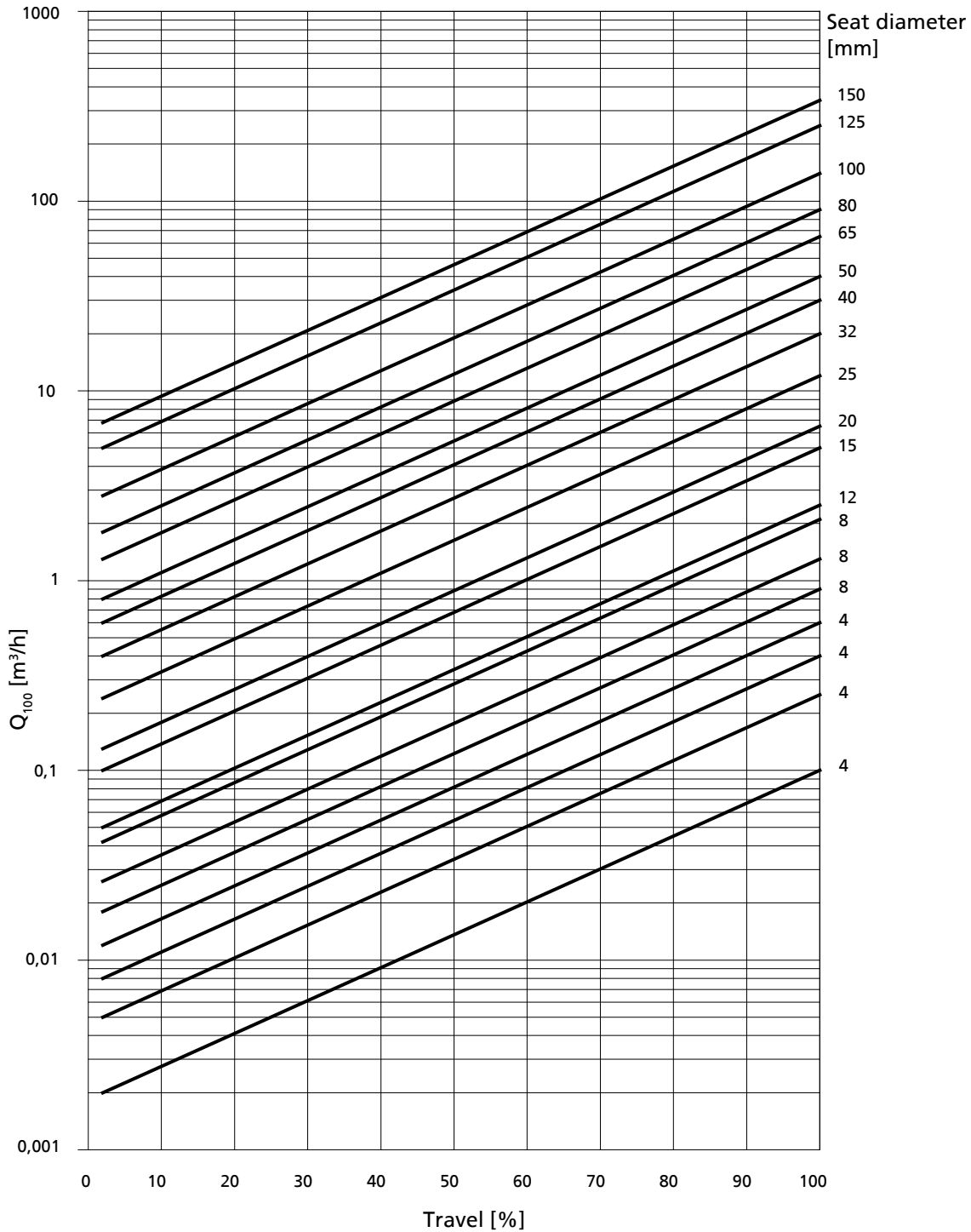

Flow coefficients

Seat diameter [mm]	4				8			12	15	20	25	32	40	50	65	80	100	125	150
Kvs value [m³/h]	0.10	0.25	0.40	0.60	0.90	1.30	2.10	2.50	5	6.5	12	20	30	40	65	90	140	250	340

Linear characteristics, rangeability 50:1

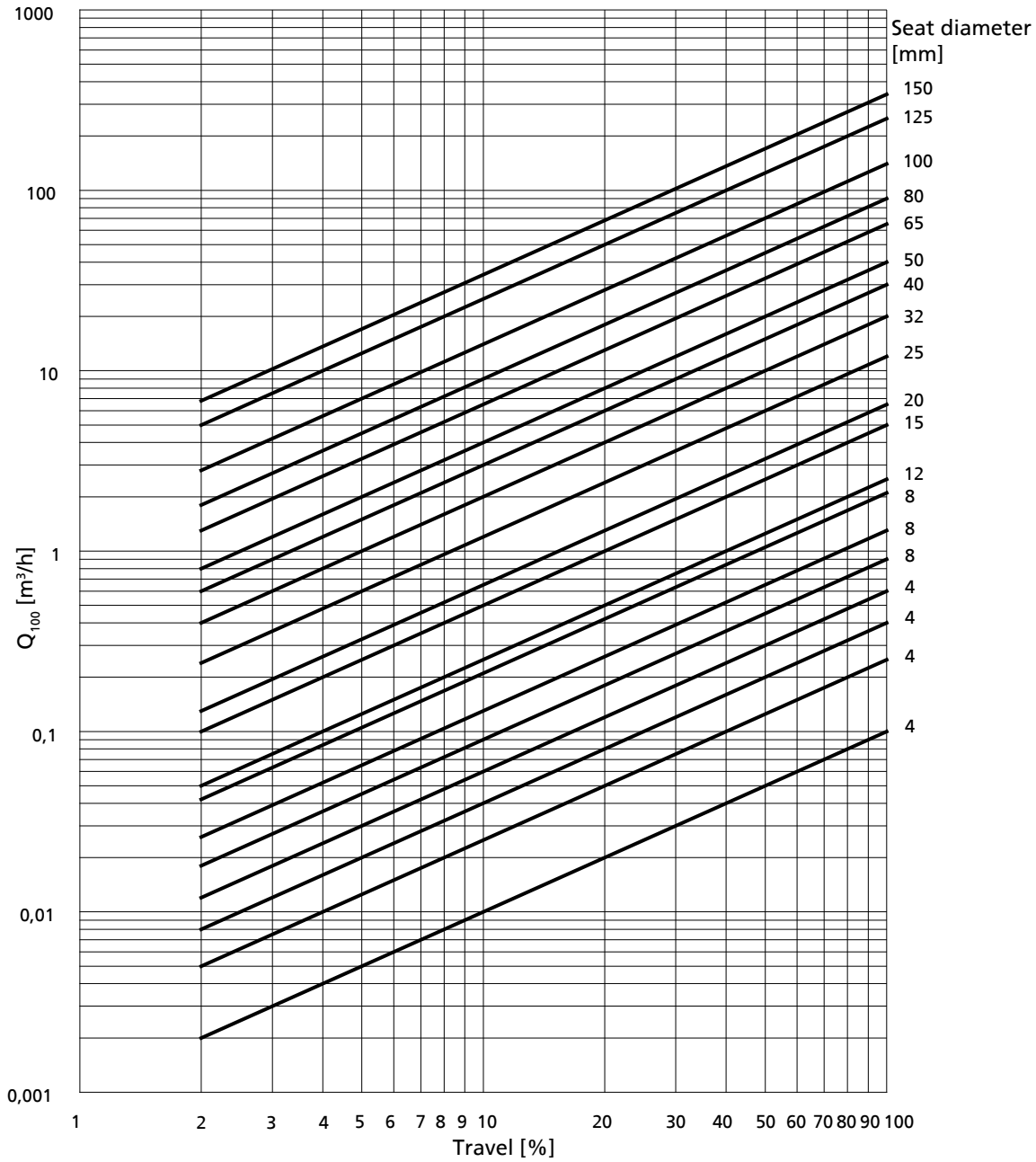

Flow coefficients

Seat diameter [mm]	4				8			12	15	20	25	32	40	50	65	80	100	125	150
Kvs value [m³/h]	0.10	0.25	0.40	0.60	0.90	1.30	2.10	2.50	5	6.5	12	20	30	40	65	90	140	250	340

**Technical data**
**Technical data - control valve**

BOA-CVE H

Nominal pressure	PN 16, PN 25
Valve characteristic	Equal-percentage, linear
Leakage class	IV: 0.01 % of $k_{vs}$ value to DIN EN 60534-4 VI (optional): to DIN EN 60534-4
Permissible pressure	16 bar, 25 bar
Flanged ends	PN 16 and PN 25 to DIN EN 1092-2
Fluid temperature	-10 to +350 °C

**Technical data - actuators**

EA-C 20...140 actuators

Type of actuator		EA-C 20...140 continuous-action	EAC 20...140 3-point (Open/Stop/Closed)
Power supply	Power supply	24 V AC $\pm$ 10 % 230 V AC $\pm$ 10 %	230 V AC $\pm$ 10 %
	Max. power input	100 VA	100 VA
Functional data	Max. actuation force	2000 N/4500 N/8000 N/14000 N	2000 N/4500 N/8000 N/14000 N
	Actuating speed	EA-C 20...40: 0.45 - 0.9 mm/s EA-C 80: 0.3 - 0.6 mm/s EA-C 140: 0.65 - 1.3 mm/s	EA-C 20...80: 0.5 mm/s EA-C 140: 0.45 mm/s
Signal inputs	Voltage	0/2 - 10 V DC	
	Input resistance	100 k $\Omega$	
	Current	4 - 20 mA	
	Input resistance	100 k $\Omega$	
	Binary input (3-point)	24 V AC	
Signal outputs	Voltage	0/2 - 10 V DC	
	Current load	max. 1 mA	
	Current	4 - 20 mA	
Type of enclosure		IP 65 to EN 60529	IP 65 to EN 60529
Environment	Operation		
	Temperature	-20 to +60 °C	-20 to +60 °C
	Humidity	5 to 95 % rH	5 to 95 % rH
	Storage		
	Temperature	-20 to +80 °C	-20 to +80 °C
	Humidity	5 to 95 % rH	5 to 95 % rH
Standards and directives	Conformity with EC standards: EC electromagnetic compatibility directive EC directive on low-voltage equipment		
Dimensions	See outline drawings		
Power cable		Terminal box max. 2.5 mm <sup>2</sup>	Direct connection to printed circuit board max. 2.5 mm <sup>2</sup>

Materials

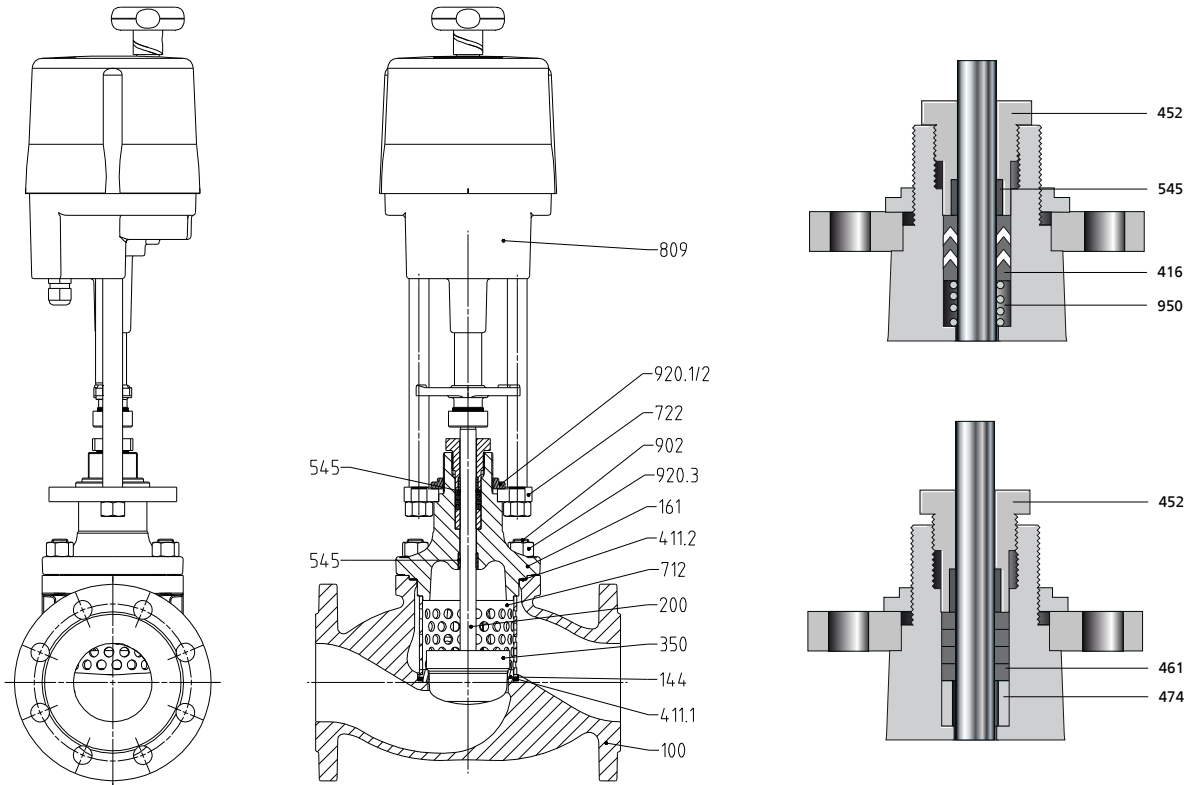

DN 20-150 with actuator type: EA-C...

Overview of available materials

Part No.	Description	Material	Material number
100	Body	EN-GJS-400-18-LT	JS 1025
144	Seat	X6CrNiMoTi17-12-2	1.4571
161	Bonnet	EN-GJS-400-18-LT	JS 1025
200	Stem	X6CrNiMoTi17-12-2	1.4571
350	Valve disc	X6CrNiMoTi17-12-2	1.4571
411.1	Seat gasket	Pure graphite	
411.2	Bonnet gasket	CrNiSt/graphite	
416	V-rings with spring	Carbon PTFE	
452	Gland follower	X5CrNi18-10	1.4301
461	Gland packing	Graphite	
474	Thrust ring	X5CrNi18-10	1.4301
545	Bearing bush	Sint A50	
75-10	Multi-hole cage	X5CrNi18-10	1.4301
722	Top flange	Steel	
809	Actuator		
902	Stud	21CrMoV5-7	1.7709
920.1	Hexagon nut	Galvanised steel	
920.2	Keywayed nut	Galvanised steel	
920.3	Hexagon nut	25CrMo4	1.7218+QT+A2D
950	Spring	X5CrNi18-10	1.4301

Dimensions

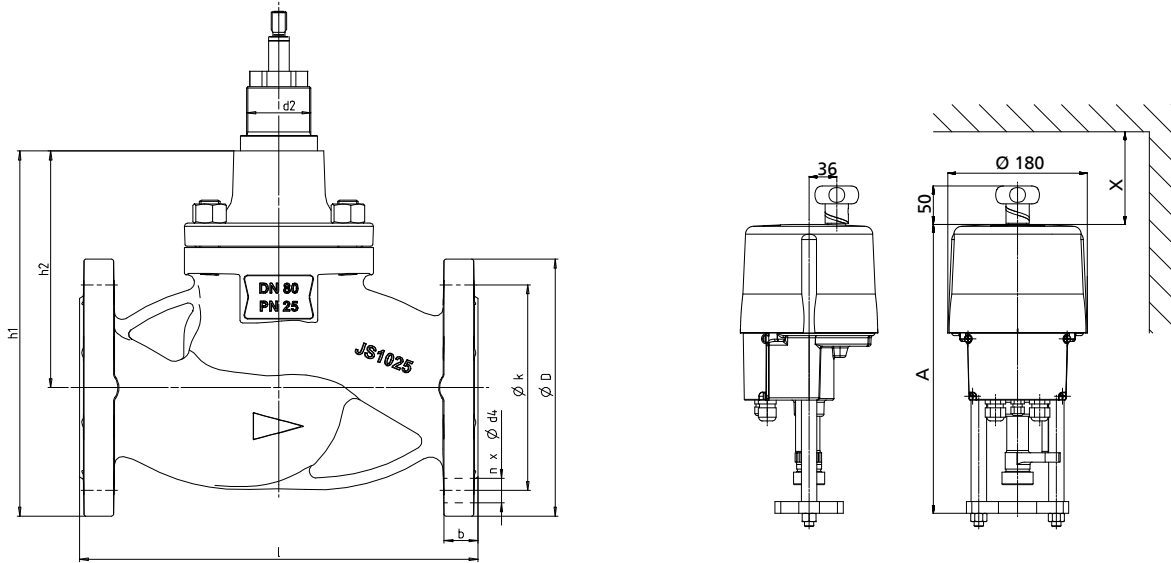

Dimensions of BOA-CVE H control valve

Dimensions in mm

PN	DN	l	h <sub>1</sub>	h <sub>2</sub>	d <sub>2</sub>	D	b	k	n	d <sub>6</sub>	[kg]
16	20	150	153.5	101.0	M39	105	16	75	4	14	6.3
	25	160	164.5	107.0	M39	115	16	85	4	14	6.9
	32	180	216.0	146.0	M39	140	18	100	4	19	10.4
	40	200	226.0	151.0	M39	150	18	110	4	19	11.6
	50	230	227.0	144.5	M39	165	20	125	4	19	13.8
	65	290	272.5	180.0	M50	185	20	145	4	19	22.3
	80	310	284.0	184.0	M50	200	22	160	8	19	28.4
	100	350	328.0	218.0	M50	220	24	180	8	19	38.4
	125	400	384.5	259.5	M50	250	26	210	8	19	60.5
	150	480	403.5	261.0	M50	285	26	240	8	23	83.0
25	20	150	153.5	101.0	M39	105	16	75	4	14	6.3
	25	160	164.5	107.0	M39	115	16	85	4	14	6.9
	32	180	216.0	146.0	M39	140	18	100	4	19	10.4
	40	200	226.0	151.0	M39	150	18	110	4	19	11.6
	50	230	227.0	144.5	M39	165	20	125	4	19	13.8
	65	290	272.5	180.0	M50	185	20	145	8	19	22.3
	80	310	284.0	184.0	M50	200	22	160	8	19	32.4
	100	350	335.5	218.0	M50	235	24	190	8	23	42.4
	125	400	394.5	259.5	M50	270	26	220	8	23	67.5
	150	480	411.0	261.0	M50	300	26	250	8	23	91.5

Dimensions of electric actuator types EA-C 20 to EA-C 140

Dimensions in mm

Actuator	Actuating force [kN]	A	X	[kg]		
				continuous-action 24 V AC	continuous-action 230 V AC	3-point 230 V AC
EA-C 20	2000	425	120	6.0	7.0	7.0
EA-C 40	4500	425	120	6.0	7.0	7.0
EA-C 80	8000	455	120	9.0	10.0	10.0
EA-C 140	14000	520	120	10.0	10.0	10.0

Mating dimensions - Standards

Face-to-face lengths: EN 558-1/1, ISO 5752/1  
 Flanges: DIN EN 1092-2, flange type 21-2  
 Flange facing: DIN EN 1092-2, type B

### Installation instructions

- Flow through BOA-CVE H control valves should be in the direction of the embossed arrow on the valve body as standard. An alternating direction of flow is permissible; however, if fluid flow does not comply with the flow direction arrow on the valve body, the actual throughflow will be lower than the maximum throughflow indicated on the name plate.
- Recommendation: A strainer fitted upstream of the valve will further enhance the valve's functional reliability.

Installation positions:

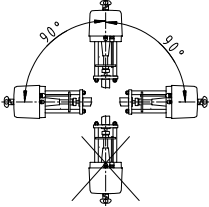

**i** EN 1515-4 "Selection of bolting for equipment subject to the Pressure Equipment Directive 97/23/EC" and any plant regulations governing the application in question must be observed when selecting connecting elements between the valve flange and the pipe flange.

### Further installation instructions

Electrical connection must be effected in accordance with the applicable local regulations for electrical installations and the equipment wiring and/or terminal plans. (⇒ Page 15)

The safety instructions and requirements for the protection of persons and equipment must always be complied with.

The permissible temperatures must be complied with (⇒ Page 9).

Service work on the actuator:

Switch off the pump and disconnect the power supply. Close the pipeline's shut-off valve, release the pressure in the piping and let the system cool down. Disconnect the electrical connections from the terminals.

Variants

Anti-cavitation design

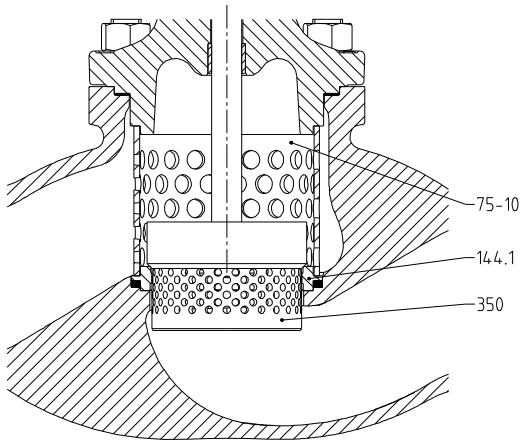

On this design variant, the fluid enters the valve in closing direction. The perforated plug (350), which defines the required characteristic curve, is guided in the seat (144.1). The bubbles implode inside the perforated plug (350), so that cavitation damage is avoided. This design variant is mainly used for liquid fluids and high differential pressures.

Balanced plug

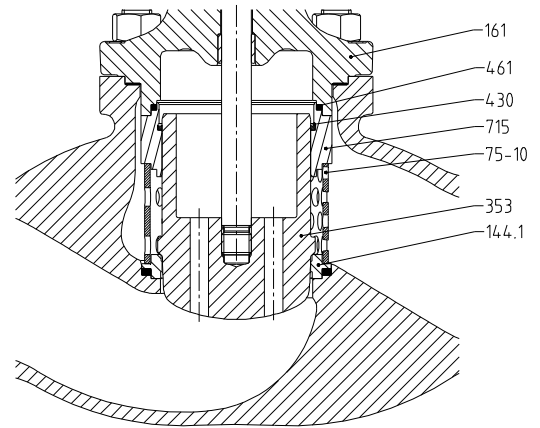

A balanced plug (353) is required if the differential closing pressures ( $\Rightarrow$  Page 4) are exceeded on globe valves of DN65 or higher. The plug is guided like a piston in the guide tube (715). Owing to the holes in the plug base, the pressure also acts on the rear side of the plug, which minimises the forces acting on the plug. Sealing in the guide tube is effected by a U-ring (430) and packing ring (461).

Seat with PTFE ring

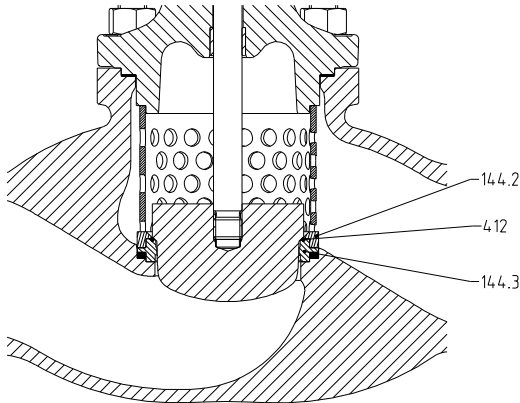

On valves designed for leakage class VI, sealing of the seat/disc interface is effected by means of a PTFE O-ring (412) held in its recess by the lower seat component (144.3) and the upper seat component (144.2).

**Overview of actuator models**

- Limit switching force-dependent in closing direction and stroke-dependent in opening direction on continuous-action actuators.
- Switching via limit switches in closing and opening direction on 3-point (Open/Stop/Closed) actuators (230 V).
- Delivered programmed to match required operating data.
- Initial adaptation to the valve.
- Operating data stored in permanent memory.
- After a power failure, operation is continued in accordance with the operating data.
- Actuator and valve coupled via stem coupling.
- Stroke indication on adhesive scale sticker.
- Optional integrated process controller (EA-C 20 to EA-C 140). A parameterisation kit is required to change the process controller's parameters.
- Actuators connected via terminal box or directly to printed circuit board.
- Actuating time between 23 and 150 seconds, depending on the  $K_{vs}$  value (stroke).
- Manual adjustment via handwheel.
- CE conformity marking

Overview of actuators

	Continuous-action	3-point
Control signal	Options	0 - 10 V
		2 - 10 V
		4 - 20 mA
Actual-position feedback	Options	24 V AC
		230 V AC
		-
Supply voltage	Options	0 - 10 V
		2 - 10 V
		4 - 20 mA
Supply voltage	24 V AC	24 V AC
	230 V AC	230 V AC
Actuating time	Selectable in increments	Fixed
Accessories	Process controller	-
	Power back-up unit	-
	Actuator heating	Actuator heating

**Process controller**

Process controller for continuous-action actuators (EA-C 20 to EA-C 140)

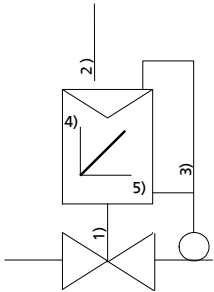

1)	Actuator stroke	2)	Setpoint Y	3)	Volume flow rate $Q_{actual}$	4)	Q	5)	Y
----	-----------------	----	------------	----	-------------------------------	----	---	----	---

The EA-C... actuator can be equipped with an integrated process controller, which may be used as a constant-variable controller for an independent control loop.

Possible applications:

- Constant-temperature control
- Volume flow rate control

The control parameters of the PI (proportional-integral) controller can be configured at the site using a parameterisation kit (Mat. No. 46001269). The setpoint signal and the sensor signal must have the same measuring range.

The sensor used must supply an active signal (e.g 4-20 mA or 0/2 to-10 V). The setpoint can be set externally via an active signal, or the device can be supplied with an internal setpoint as per customer specification.

**Wiring diagrams**
**Terminal configuration EA-C 20 to 140 24 V AC for model with terminal box**
**Continuous-action actuation 24 V AC**

1	2	3	4	5	6	7	8	9	10	11	12	13	14	15	16	17	18	19	20	21	22	23			RJ-45 TTL	Push-button	
↑	↑	↑	↓	↓	↓	↑↑	↑↓	↑	↑	↑	↑	↑	↓	↑	↑	↑	↑↑	↑↑	↑↑	↑↑	↑↓	↑	↑	PE	(Optional)		
+0(2) - 10 V	+0(4) - 20 mA	GND	+0(2) - 10 V	+0(4) - 20 mA	GND	Max. load 100 mA at 24 VDC		L OPEN	N	L CLOSE	L (24 V AC/DC)	N (24 V AC/DC)	24 V DC / 100 mA	+0(2) - 10 V	+0(4) - 20 mA	GND	(Optional)	(Optional)	(Optional)	(Optional)	L (see name plate)	N (see name plate)		(Optional)			
(A)			(B)			(C)		(D)			(E)	(F)	(G)				(H)		(I)		(J)		(K)	(L)	(M)		
(N)						(O)						(P)															

**i** In continuous-action configuration, only the terminals in columns (A), (B) and (J) are active!

**3-point (Open/Stop/Closed) actuation 24 V AC**

1	2	3	4	5	6	7	8	9	10	11	12	13	14	15	16	17	18	19	20	21	22	23			RJ-45 TTL	Push-button	
↑	↑	↑	↓	↓	↓	↑↑	↑↓	↑	↑	↑	↑	↑	↓	↑	↑	↑	↑↑	↑↑	↑↑	↑↑	↑↓	↑	↑	PE	(Optional)		
+0(2) - 10 V	+0(4) - 20 mA	GND	+0(2) - 10 V	+0(4) - 20 mA	GND	Max. load 100 mA at 24 VDC		L OPEN	N	L CLOSE	L (24 V AC/DC)	N (24 V AC/DC)	24 V DC / 100 mA	+0(2) - 10 V	+0(4) - 20 mA	GND	(Optional)	(Optional)	(Optional)	(Optional)	L (see name plate)	N (see name plate)		(Optional)			
(A)			(B)			(C)		(D)			(E)	(F)	(G)				(H)		(I)		(J)		(K)	(L)	(M)		
(N)						(O)						(P)															

**i** In 3-point (Open/Stop/Closed) configuration, only the terminals in columns (B), (D) and (J) are active!

**Key**

(A)	Setpoint input	(I)	Open
(B)	Active actual-position feedback	(J)	Power supply
(C)	Volt-free fault message	(K)	Fieldbus connection
(D)	Binary control	(L)	Communication with PC
(E)	Power failure signal	(M)	Commissioning
(F)	Supply	(N)	Galvanically isolated 1 kV
(G)	Actual value	(O)	Process sensor
(H)	Closed	(P)	Limit switch, volt-free contact

Terminal configuration EA-C 20 to 140 230 V AC

Continuous-action actuation 230 V AC

1	2	3	4	5	6	7	8	9	10	11	12	13	14	15	16	17	18	19	20	21	22	23		RJ-45 TTL	Push- button	
↑	↑	↑	↓	↓	↓	↑↓	↑↓	↑	↑	↑	↑	↑	↓	↑	↑	↑	↑↓	↑↓	↑↓	↑↓	↑	↑	↑	PE	(Optional)	
+0(2) - 10 V	+0(4) - 20 mA	GND	+0(2) - 10 V	+0(4) - 20 mA	GND	100 mA at 24 VDC	Max. load	L OPEN	N	L CLOSE	L (24 V AC/DC)	N (24 V AC/DC)	24 V DC / 100 mA	+0(2) - 10 V	+0(4) - 20 mA	GND	(Optional)	(Optional)	(Optional)	(Optional)	L (see name plate)	N (see name plate)				
(A)		(B)		(C)		(D)		(E)		(F)	(G)	(H)		(I)		(J)		(K)	(L)	(M)						
(N)						(O)						(P)														

In continuous-action configuration, only the terminals in columns (A), (B) and (J) are active!

Key

(A)	Setpoint input	(I)	Open
(B)	Active actual-position feedback	(J)	Power supply
(C)	Volt-free fault message	(K)	Fieldbus connection
(D)	Binary control	(L)	Communication with PC
(E)	Power failure signal	(M)	Commissioning
(F)	Supply	(N)	Galvanically isolated 1 kV
(G)	Actual value	(O)	Process sensor
(H)	Closed	(P)	Limit switch, volt-free contact

3-point (Open/Stop/Closed) actuation 230 V AC

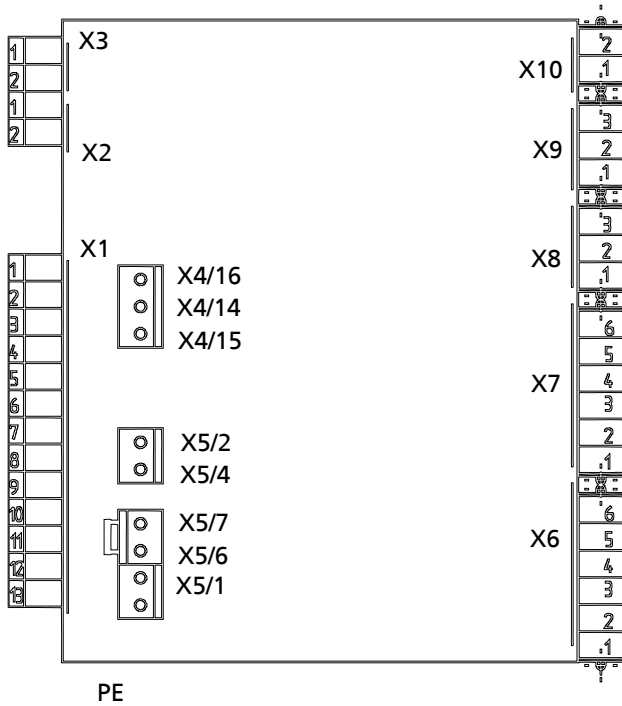

Key

X1	Internal wiring
X2	Internal wiring
X3	Internal wiring
X4	Potentiometer 1
X5/1	Neutral
X5/2	Motor phase to open
X5/4	Motor phase to close
X5/6 und X5/7	Thermal circuit breaker as volt-free contact
X6	Additional limit switches
X7	Not used
X8	Heating resistor
X9	Potentiometer 2
PE	Earth connection on housing

1)

2)

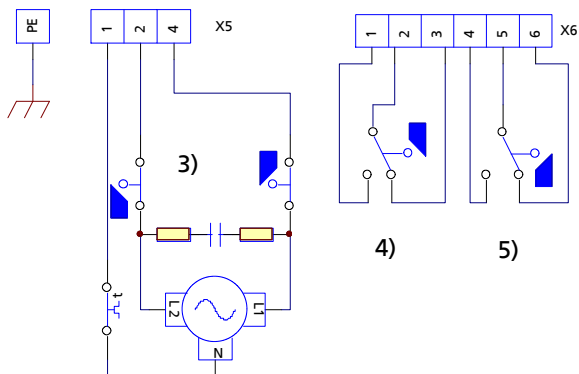

1)	1-phase AC	4)	Closed
2)	Additional limit switches	5)	Open
3)	Position		

Specification sheet for valve selection

Operating data for selecting the control valve, type: BOA-CVE H

	Point of control	Control task			Potentially explosive atmosphere (zone)	
	<b>Ambient temperature</b>	[°C]	Max.		Min.	
Max. permissible sound pressure level	[dB(A)]					
<b>Pipe</b>	-	DN		PN		
<b>Fluid handled</b>	-					
State when entering valve	-	Liquid		Steam		
	-	Gas				
Process data		Min.	<b>Normal</b>	Max.		
	<b>Volume flow rate (liquid)</b>	[m³/h]				
	<b>Mass flow rate (gas/steam)</b>	[kg/h]				
	<b>Inlet temperature</b>	[°C]				
	<b>Inlet pressure (a) p1</b>	[bar]				
	<b>Outlet pressure (a) p2</b>	[bar]				
	Inlet density	[kg/m³]				
	Kinematic viscosity	[cSt]				
Valve data	<b>Flow direction</b>	-	Δp opens		Δp closes	
	<b>Nominal size, nominal pressure</b>	-	DN		PN	
	<b>Line connection/Pattern</b>	-	Straight-way pattern, raised-face flange, type B (DIN 1092-2)			
	<b>Body/bonnet material</b>	-	Nodular cast iron EN-GJS-400-18-LT			
	<b>Characteristic</b>	-	Linear		Equal-percentage	
	Selected flow coefficient	kv <sub>s</sub> value				
	Seat/disc diameter	[mm]				
	Packing material	-	PTFE		Graphite	
	<b>Leakage class (DIN EN 60534-4)</b>	-	IV		VI	
	<b>Δp closes (actuator selection)</b>	[bar]				
Actuator data (electr.)	<b>Actuator function/Power supply</b>		Continuous 24V or 230V		3-point 24V	3-point 230V <sup>5)</sup>
	Actuating time					
	<b>Position value</b>		Setpoint	Actual	Actual	
		DC 0-10V				
		DC 2-10V				
0-20 mA						
	4-20 mA					

The data in bold is mandatory in all RFQs.

5) Actual-position feedback via two integrated limit switches

**Chemical resistance chart**

The information provided in this chemical resistance chart is based on experience, the Dechema lists as well as manufacturer information. Corrosion resistance is largely dependent on the operating conditions, temperatures and concentrations. Hydroabrasive wear in fluids containing solids is not covered in this list. All information provided herein, therefore, only serves as an orientation. Warranty claims may not be asserted on the basis of this list!

**Chemical resistance chart for water**

Fluid handled	Max. content	Max. temp.	
Brackish water <sup>6)7)</sup>			✗
Service water <sup>6)7)</sup>			✓
Fire-fighting water <sup>6)</sup>			✓
Chlorinated water <sup>6)</sup>	0,6 mg/kg		✓
Deionised water (demineralised water)			✗
Distilled water			✗
Boiler feed water <sup>8)</sup>			✓
Hot water <sup>6)</sup>			✓
High-temperature hot water <sup>8)</sup>		T = f (p)	✓
Condensate <sup>8)</sup>			✓
Oil-free cooling water <sup>6)</sup>			✓
Oil-containing cooling water <sup>6)</sup>			✓
Ozonised water <sup>6)</sup>	0.5 mg/kg		✓
Pure water <sup>6)</sup>			✓
Seawater			✗
Scale-forming water <sup>6)7)</sup>			○
Raw water <sup>6)7)</sup>			✓
Partly desalinated water			✗
Fully desalinated water			✗
Municipal waste water <sup>7)9)</sup>			✓
Industrial waste water <sup>7)10)</sup>			✓

**Chemical resistance chart for oils (aromatic content 5 mg/kg)**

Fluid handled	Max. content	Max. temp.	
Vegetable oils			✓
Mineral oils			✓
Synthetic oils			✓
Crude oil			✓
Petroleum			✓
Light fuel oil			✓
Heavy fuel oil			✓
Linseed oil			✓
Oil-water emulsion <sup>7)</sup>			✓
Jet fuel			✓
Petrol			✓
Kerosene			✓

**Chemical resistance chart for refrigerants**

Fluid handled	Max. content	Max. temp.	
Ammonium hydroxide	30 %	25 °C	✓
Glycol (ethylene glycol)			✓
Propylene glycol			✓
Water-glycol mixture	50 %	40 °C	✓
Inorganic cooling brine, ph 7.5 inhibited			✓

**Chemical resistance chart for thermal oils**

Fluid handled	Max. content	Max. temp.	
Synthetic thermal oils			✓
Mineral-based thermal oils			✓

**Chemical resistance chart for acids**

Fluid handled	Max. content	Max. temp.	
Hydrochloric acid			✗
Sulphuric acid (pure, techn., concentr.)			✗
Sulphuric acid			✗
Fatty acid			✗
Nitric acid			✗

**Chemical resistance chart for cleaning agents**

Fluid handled	Max. content	Max. temp.	
Lye for bottle rinsers (e.g. P3) <sup>7)</sup>		≤ 80 °C	○
Lye for metal cleaning <sup>7)</sup>		≤ 80 °C	○

**Chemical resistance chart for steam**

Fluid handled	Max. content	Max. temp.	
Saturated steam			✓

**Chemical resistance chart for other fluids**

Fluid handled	Max. content	Max. temp.	
Sodium hydroxide	< 50 %	≤ 50 °C	○
Natural gas			✓
Oil-containing compressed air			✓
Dry chlorine		≤ 30 °C	✓
Ammonia			✓
Butane (liquefied gas)			✓
Aqueous glycerine			✓
Carbon dioxide (gas)			✓
Carbon dioxide (aqueous solution)			✗

6) General limits for water to be handled by valves made of non-alloyed materials: pH value 6.5 - 12; chloride ions (Cl) < 150 mg/kg; chlorine (Cl<sub>2</sub>) < 0.6 mg/kg.

7) Without solids

8) Water treatment must be in compliance with the guidelines for feed water (e.g. VdTÜV 1466, TRD 611, etc.): pH value ≥ 9.0; O<sub>2</sub> content ≤ 0.02 mg/l

9) Biologically treated

10) Non-corrosive, non-abrasive

Key to the symbols

Symbol	Description
✓	The fluid handled is not normally aggressive toward the materials.
✘	The fluid handled is aggressive toward the materials. Valve cannot be used.
○	The material or valve can only be used under certain operating conditions. Please enquire accordingly, stating the operating conditions such as concentration, temperature, pH value and composition of the fluid handled.





**KSB Aktiengesellschaft**

Johann-Klein-Straße 9 • 67227 Frankenthal (Germany)

Tel. +49 6233 86-0 • Fax +49 6233 86-3882

E-Mail: [valves@ksb.com](mailto:valves@ksb.com) • [www.ksb.com](http://www.ksb.com)