

Globe Valve

BOA-H/HE/HV/HEV

PN 25/40
DN 10-350
Bellows
Flanges/weld ends
or socket weld ends

Type Series Booklet



Legal information/Copyright

Type Series Booklet BOA-H/HE/HV/HEV

KSB Aktiengesellschaft

All rights reserved. The contents provided herein must neither be distributed, copied, reproduced, edited or processed for any other purpose, nor otherwise transmitted, published or made available to a third party without KSB's express written consent.

Subject to technical modification without prior notice.

© KSB Aktiengesellschaft Frankenthal 2012

Globe Valves

Bellows-type Globe Valves

BOA-H/HE/HV/HEV

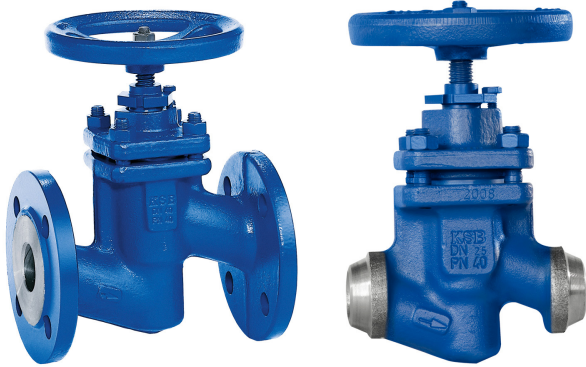

Main applications

- Process engineering
- Chemical industry
- Petrochemical industry
- Sugar industry
- Heat recovery systems
- Boiler recirculation
- Boiler feed applications

Fluids handled

- Water
- Steam
- Gas
- Thermal oil
- Liquids not chemically or mechanically aggressive to the valve materials.
- Other fluids on request.

Operating data

Operating properties

Characteristic	Value
Nominal pressure	PN 25/40
Nominal size	DN 10-350 ¹⁾
Max. permissible pressure	40 bar
Max. permissible temperature	450 °C

Selection as per pressure/temperature ratings (⇒ Page 4)

¹⁾ DN 250-350, type BOA-HV/HEV

Design details

Design

- Straight-way pattern
- On/off disc
- Seat/disc interface made of wear and corrosion-resistant chrome steel (Cr) or chrome nickel steel (CrNi)
- Outside screw
- Back seat
- Stem sealed by double-walled bellows and back-up gland packing
- EC type-tested (Module B), component mark TÜ.A./AR-291
- Exterior coating: blue RAL 5002
- The valves meet the requirements specified in TA-Luft (German Technical Guidelines on Air Quality Control, VDI 2440).
- The valves satisfy the safety requirements of Annex I of the European Pressure Equipment Directive 97/23/EC (PED) for fluids in Groups 1 and 2.
- The valves do not have a potential internal source of ignition and can be used in potentially explosive atmospheres, Group II, category 2 (zones 1+21) and category 3 (zones 2+22) to ATEX 94/9/EC.

Variants

- Throttling plug
- Pilot plug for DN 250-350 (for DN 125-200 NORI 40)
- Position indicator (standard for DN 250-350)
- Studs and nuts of A4-70 (low-temperature steel)
- Cap
- Oil and grease-free (wetted parts)
- Other flange designs or butt weld end versions
- Inspections to technical codes such as TRD/TRB/AD2000 – German Steam Boiler / Pressure Vessel Regulations – or to customer specification

Body materials

Overview of available materials

Material	Material number	Temperature limit
P 250 GH	1.0460	Up to 450 °C
GP 240 GH+N	1.0619+N	Up to 450 °C

Product benefits

- Reliable sealing: bonnet gasket fully confined to prevent creep.
- Improved energy efficiency of the system. Short, easy-to-insulate bonnet minimises heat losses.
- Additional stem seal for emergency operation and blow-out protection by standard back seat as well as back-up gland packing made of pure graphite.
- Hard-faced valve seat made of wear-resistant and corrosion-proof materials for long service life and high functional reliability.

- Corrosion-resistant and easy to repair due to olive-chromated nuts and bolts/screws.

Related documents

- We recommend using our maintenance-free DN 10-200 NORI 40 globe valves, types ZXLB and ZXSB, if actuators are to be mounted (see type series booklet 7165.1).
- Operating manual 0570.82

On all enquiries/orders please specify

1. Type
2. Nominal pressure
3. Nominal size
4. Operating pressure
5. Differential pressure
6. Operating temperature
7. Fluid handled
8. Pipe connection
9. Variants
10. Number of type series booklet

Pressure/temperature ratings

Permissible operating pressures in bar at a temperature of °C (to EN 1092-1)²⁾

Nominal pressure PN	Material	RT ³⁾	100	150	200	250	300	350	400	450
25	P 250 GH - 1.0460	25,0	23,2	22,0	20,8	19,0	17,2	16,0	14,8	8,2
40	GP 240 GH+N - 1.0619+N	40,0	37,1	35,2	33,3	30,4	27,6	25,7	23,8	13,1
40		40,0	27,0	23,0	22,0	21,0	19,0	18,0	17,0	13,0

2) Operating pressures to DIN 2401 are also permissible

3) RT: room temperature (-10 °C to +50 °C)

4) Values deviating from EN 1092-1

Materials

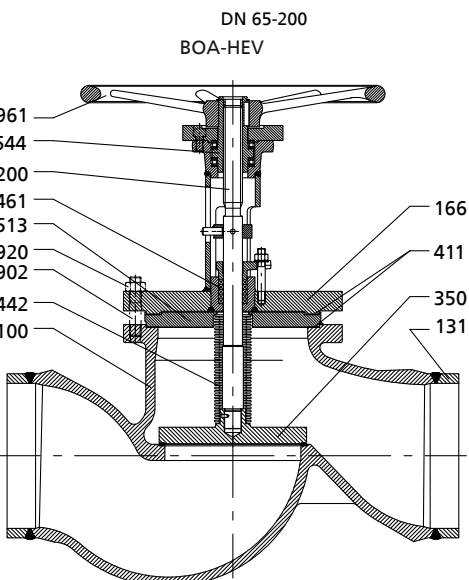
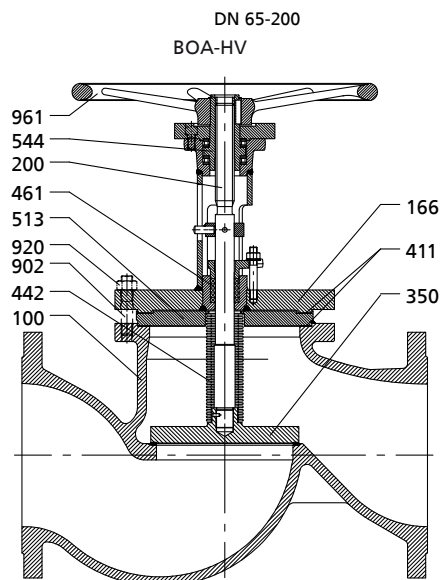
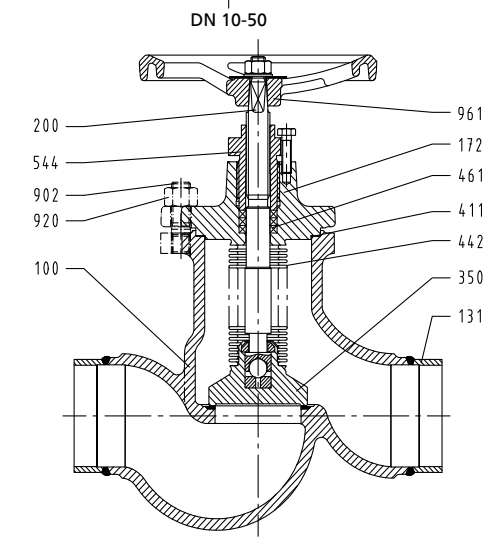
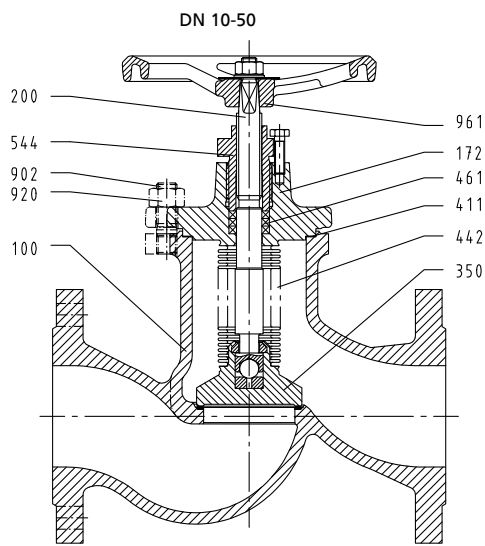
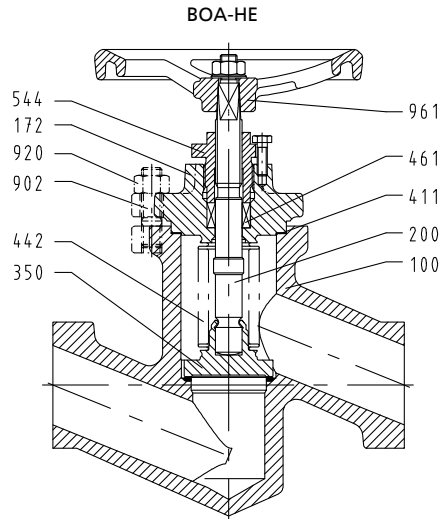
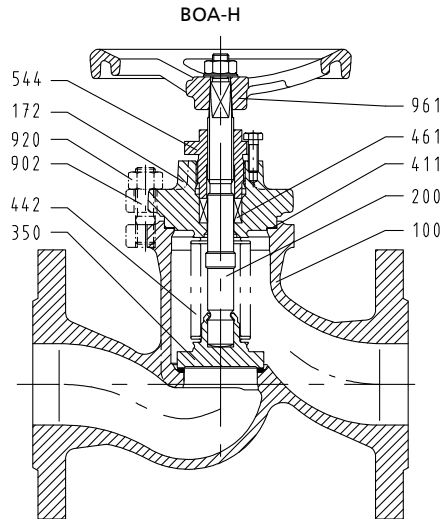

DN 250-350

DN 250-350

Overview of available materials

Part No.	Description	Material	Material number	Note	
100	Body	P250 GH	1.0460	JL1040	Hard-faced with stainless steel (1.4370)
		GP 240 GH+N	1.0619+N	BOA-H \geq DN 50, BOA-HE \geq DN 65	
131	Connection branch	P 235 GH	1.0305	\geq DN 65	Hard-faced (1.4115)
166	Yoke	P 250 GH	1.0460	DN 250	
		P265 GH	1.0425	\geq DN 300	
172	Bonnet	P 250 GH	1.0460		
200 ⁵⁾	Stem	X 20 Cr 13	1.4021	Nitrided (DN 10-100)	
350 ⁵⁾	Valve disc	X 20 Cr 13	1.4021		
		P 250 GH	1.0460	\geq DN 125	
442 ⁵⁾	Bellows	X 6 CrNiMoTi 17-12-2	1.4571		
544 ⁵⁾	Threaded bush	11 SMn 30+C	1.0715	Nitrided	
		X 39 CrMo 17-1	1.4122	Nitrided, \geq DN 250	
411 ⁵⁾	Joint ring	CrNi steel / graphite			
461 ⁵⁾	Gland packing	Graphite			
513	Insert ring	P 250 GH	1.0460	\geq DN 250	
902	Stud	21 CrMoV 5-7	1.7218		Olive-chromated
920	Hexagon nut	25 CrMo 4	1.7218		
961	Handwheel	JL 1030	0.6020		

Variants

BOA-H/HE

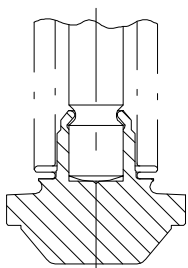

DN 10-50

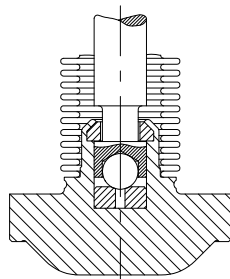

DN 65-200

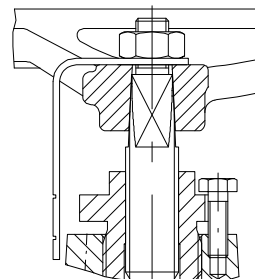

DN 10-200

Throttling plug

Position indicator

BOA-HV/HEV

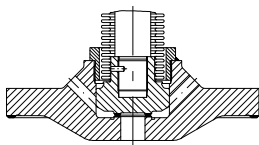

Balanced plug

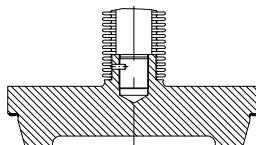

Throttling plug

⁵⁾ Recommended spare parts

Dimensions

BOA-H dimensions

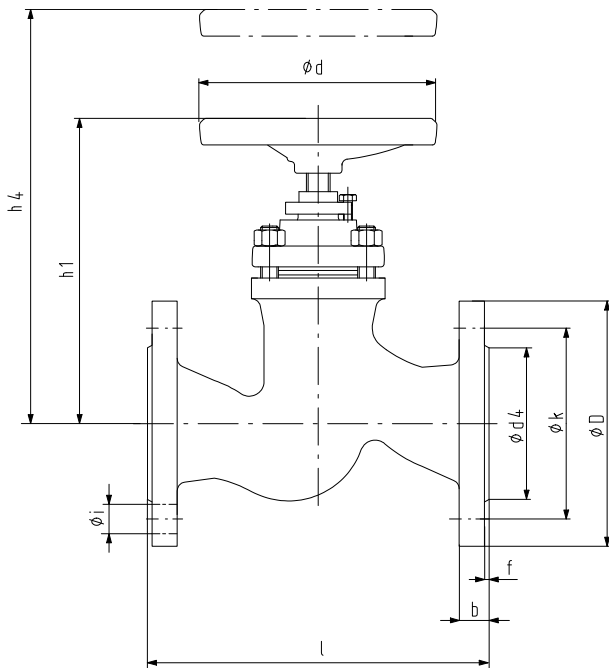

Dimensions in mm

PN	DN	l	ø D	ø k	No. of bolt holes z	Bolt hole dia. i	ø d ₄ x f	b	h ₁	h ₄	Valve travel	ø d	[kg]
25/40	10	130	90	60	4	14	40 x 2	16	140	210	4,0	125	3.8
	15	130	95	65	4	14	45 x 2	16	140	210	4,0	125	3.3
	20	150	105	75	4	14	58 x 2	18	165	260	6,5	125	4.8
	25	160	115	85	4	14	68 x 2	18	165	260	6,5	125	5.4
	32	180	140	100	4	18	78 x 2	18	190	290	8,0	160	9.1
	40	200	150	110	4	18	88 x 3	18	200	300	10,0	160	10.2
	50	230	165	125	4	18	102 x 3	20	220	330	12,5	160	13.2
	65	290	185	145	8	18	122 x 3	22	270	420	16,5	200	19.8
	80	310	200	160	8	18	138 x 3	24	305	480	20,0	200	27
	100	350	235	190	8	22	162 x 3	24	345	550	25,0	250	41.7
	125	400	270	220	8	26	188 x 3	26	395	580	31,5	315	66
150	480	300	250	8	26	218 x 3	28	430	620	37,5	315	88	
25	200	600	360	310	12	26	278 x 3	30	500	760	47,5	400	144.6
40	200	600	375	320	12	30	285 x 3	34	500	760	47,5	400	175

Mating dimensions - Standards

Face-to-face lengths: EN 558-1/1, ISO 5752/1
 Flanges: Mating dimensions to DIN EN 1092, ISO 7005
 Raised face: DIN EN 1092, type B

Other flange designs

- E.g. groove (type D), tongue (type C), recess (type F), spigot (type E) to EN 1092-1 at both ends
- Other flange designs on request

BOA-HE dimensions

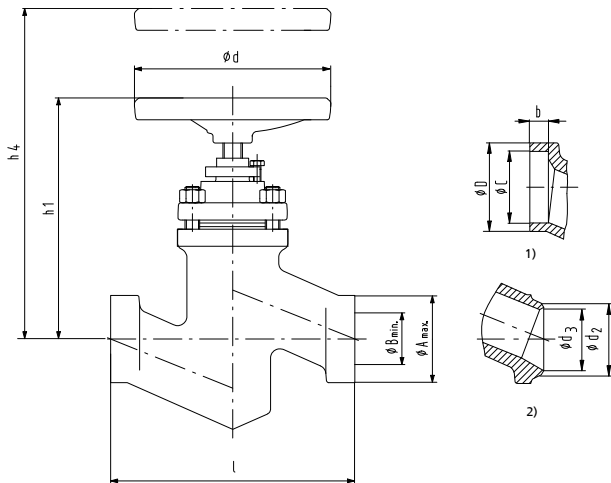

1)	Socket weld end	2)	Butt weld end
----	-----------------	----	---------------

Dimensions in mm

PN	DN	I	Butt weld ends, unmachined		Butt weld ends to DIN EN 12627			Socket weld ends to DIN EN 12760			h ₁	h ₄	Valve travel	ø d	[kg]
			ø A _{max.}	ø B _{min.}	ø d ₂	ø d ₃	Related pipe dimensions	ø D _{-0,5}	ø C ^{+0,2}	b _{min.}					
25/40	10	130	37	10	18	13	17,2 x 2,0	25	17,6	10	165	260	4,0	125	3
	15	130	37	15	22	17	21,3 x 2,0	30,5	21,7	10	165	260	4,0	125	2.9
	20	130	37	20	28	22	26,9 x 2,3	36,5	27,1	13	165	260	6,5	125	3.3
	25	130	37	24	34	28,5	33,7 x 2,6	44,5	33,8	13	165	260	6,5	125	3.2
	32	160	60	33	43	43	42,4 x 2,6	53,5	42,5	13	200	290	8,0	160	5.5
	40	180	60	38	49	43	48,3 x 2,6	60,5	48,7	13	200	300	10,0	160	5.5
	50	210	73	48	61	54	60,3 x 3,2	73,5	61,1	16	220	330	12,5	160	8.3
	65	290	76,1	64,9	76,1	69	76,1 x 3,6				270	420	16,5	200	17
	80	310	88,9	79,9	88,9	81	88,9 x 4,0				305	480	20,0	200	30
	100	350	114,3	100,1	114,3	104	114,3 x 5,0				345	550	25,0	250	40
	125	400	139,7	125,5	139,7	130,5	139,7 x 4,5				395	580	31,5	315	60
	150	480	168,3	148,3	168,3	156,5	168,3 x 5,6				430	620	37,5	315	80
200	600	219,1	199,1	219,1	204,5	219,1 x 7,1				500	760	47,5	400	130	

Mating dimensions - Standards

Face-to-face lengths: EN 12982/64
Butt weld ends: DIN EN 12627 Fig. 2
Socket weld ends: DIN EN 12760

Different designs of butt weld ends, socket weld ends and welding groove types are possible, but only within the dimensions A_{max.} and B_{min.}

Butt weld ends to DIN 3239, type 1, or socket weld ends to ASME B16.11/DIN 3239/2 possible.

BOA-HV dimensions

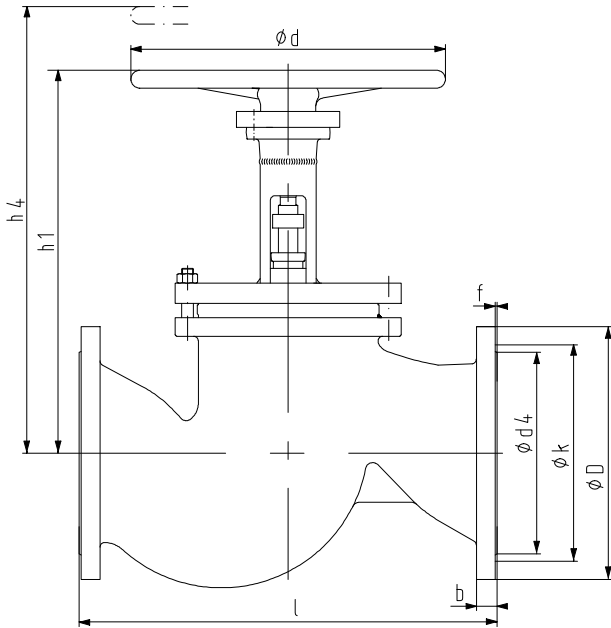

Dimensions in mm

PN	DN	l	ø D	ø k	No. of bolt holes z	Bolt hole dia. i	ø d ₄ x f	b	h ₁	h ₄	ø d	[kg]
25	250	730	425	370	12	30	335 x 3	32	705	1035	500	270
	300	850	485	430	16	30	395 x 4	34	785	1145	630	385
	350	980	555	490	16	33	450 x 4	38	950	1400	800	630
40	250	730	450	385	12	33	345 x 3	38	705	1035	500	300
	300	850	515	450	16	33	410 x 4	42	785	1145	630	430
	350	980	580	510	16	36	465 x 4	46	950	1400	800	660

Mating dimensions - Standards

Face-to-face lengths: EN 558-1/1, ISO 5752/1
 Flanges: Mating dimensions to DIN EN 1092, ISO 7005
 Raised face: DIN EN 1092, type B

Other flange designs

- E.g. groove (type D), tongue (type C), recess (type F), spigot (type E) to EN 1092-1 at both ends
- Other flange designs on request

BOA-HEV dimensions

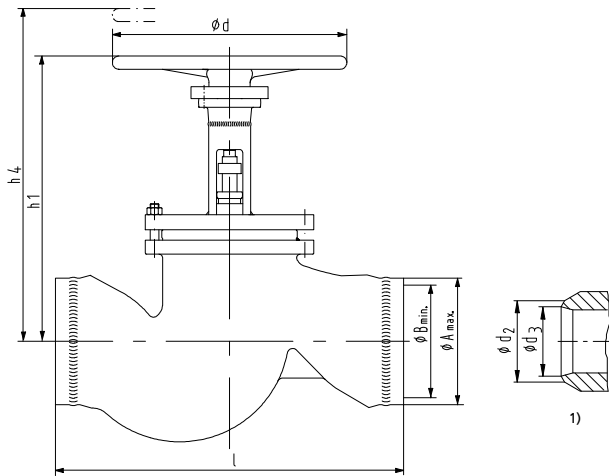

1) Butt weld end

Dimensions in mm

PN	DN	l	Butt weld ends, unmachined		Butt weld ends to DIN EN 12627			h ₁	h ₄	ø d	[kg]
			ø A _{max.}	ø B _{min.}	ø d ₂	ø d ₃	Associated pipe dimensions				
25/40	250	730	273	251	273	256,5	273,0 x 8,0	705	1035	500	260
	300	950	345	305	323,9	306,5	323,9 x 8,8	785	1145	630	290
	350	1100	385	335	355,6	336,5	355,6 x 10,0	950	1400	800	600

Mating dimensions - Standards

Face-to-face EN 12982/64 (for DN 250)
lengths: or as per table (for DN 300, 350)
Butt weld ends: DIN EN 12627 Fig. 2

Different designs of butt weld ends, socket weld ends and welding groove types are possible, but only within the dimensions A_{max.} and B_{min.}.

Dimensions of lead-sealable cap

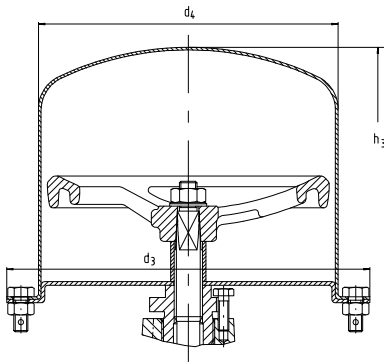

Lead-sealable cap (prevents unauthorised closing)

Dimensions in mm

Nominal size DN	d_3	d_4	h_3		[kg]
			BOA-H	BOA-HE	
10	165	130	185	205	0,8
15	165	130	185	205	0,8
20	165	130	205	205	0,8
25	165	130	205	205	0,8
32	205	170	265	275	1,6
40	205	170	275	275	1,6
50	205	170	295	295	1,6
65	256	220	385	385	2,5
80	256	220	415	415	2,5
100	390	340	455	455	6,5
125	390	340	495	495	6,5
150	390	340	520	520	6,5
200	470	420	550	550	9,0

Installation instructions

Shut-off globe valves must be installed in the line so as to ensure that the fluid enters the valve beneath the valve disc and flows out above the valve disc. They can also be installed in lines with alternating flow.

If the max. permissible differential pressures for shut-off are exceeded for valves from DN 125 to 350, a pilot plug design is required. In this case the valve must be installed in such a way that the pressure to be sealed off lies above the valve disc.

The balanced plug works on the bypass principle and can only serve its purpose if backpressure builds up after opening, so that the max. permissible differential pressures for shut-off (see table) are not exceeded.

If a pilot plug design is required for DN 125 to 200, a NORI 40 ZXLBV/ZXSbv or ZXLB/ZXSB shut-off valve must be used.

Differential pressures in bar (standard valve disc)

DN	125	150	200	250	300	350
Δp [bar]	33	21	14	9	6	4,5

For globe valves with throttling plug, detailed information about the operating mode is required for optimum valve selection.



KSB Aktiengesellschaft

Bahnhofplatz 1 • 91257 Pegnitz (Germany)

Tel. +49 9241 71-0 • Fax +49 9241 71-1795

E-Mail: valves@ksb.com • www.ksb.com