

In-line Pump

**Etaline**

50 Hz

**Type Series Booklet**



## **Legal information/Copyright**

Type Series Booklet Etaline

All rights reserved. The contents provided herein must neither be distributed, copied, reproduced, edited or processed for any other purpose, nor otherwise transmitted, published or made available to a third party without the manufacturer's express written consent.

Subject to technical modification without prior notice.

© KSB Aktiengesellschaft, Frankenthal 21.07.2016

Contents

**Heating / Air-conditioning / Ventilation ..... 4**

  In-line Pumps ..... 4

    Etaline ..... 4

      Main applications ..... 4

      Fluids handled ..... 4

      Operating data ..... 4

      Designation ..... 4

      Design details ..... 4

      Materials ..... 5

      Coating and preservation ..... 6

      Product benefits ..... 6

      Product information as per Regulation No. 547/2012 (for water pumps with a maximum shaft power of 150 kW) implementing "Ecodesign" Directive 2009/125/EC ..... 6

      FluidFuture energy efficiency concept developed by KSB ..... 6

      Acceptance tests and warranty ..... 6

      Overview of fluids handled ..... 7

      Pressure limits and temperature limits ..... 8

      Technical data ..... 8

      Selection charts ..... 12

      Characteristic curves ..... 14

      Dimensions and connections ..... 51

      Flange design ..... 59

      Typical installation positions ..... 60

      Accessories ..... 62

      General assembly drawings ..... 64

      Detailed designation ..... 69

## Heating / Air-conditioning / Ventilation

### In-line Pumps

## Etaline

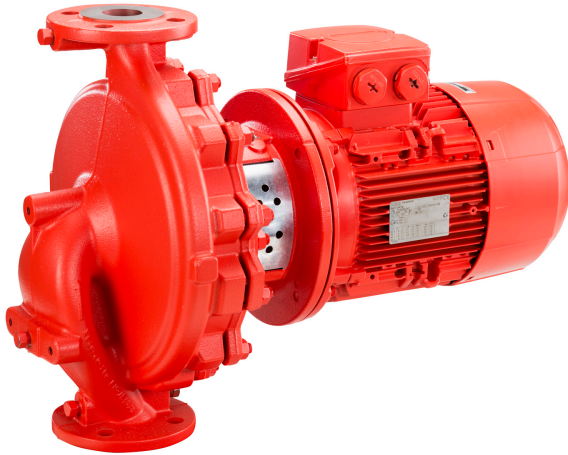

### Main applications

- Heating systems
- Air-conditioning systems
- Cooling circuits
- Water supply systems
- Service water supply systems
- Industrial recirculation systems
- Swimming pools

### Fluids handled

- Fluids not chemically or mechanically aggressive to the materials

### Further information on fluids handled

(⇒ Page 7)

### Operating data

Operating properties

Characteristic		Value
Flow rate	Q [m³/h]	700
	Q [l/s]	194
Head	H [m]	96
Fluid temperature	T [°C]	-30 to +140
Operating pressure	p [bar]	≤ 16

### Designation

Example: ETL 050-050-160 GG X AA 06 D 2

Designation key

Code	Description
ETL	Type series
	ETL   Etaline
050	Nominal suction nozzle diameter [mm]
050	Nominal discharge nozzle diameter [mm]
160	Nominal impeller diameter [mm]
G	Casing material
	G   Grey cast iron
G	Impeller material if different from casing material
	G   Grey cast iron
	C   Stainless steel
B   Bronze	
X	Additional code
	X   Special design
A	Casing cover
	A   Conical seal chamber
A	Sealing system
	A   Conical seal chamber
V   Conical seal chamber with vent	
06	Seal code
	06   Mechanical seal material U3BEGG (SU 25, 35)
	07   Mechanical seal material Q1Q1EGG
	09   Mechanical seal material U3U3VGG
	10   Mechanical seal material Q1Q1X4GG
	11   Mechanical seal material BQ1EGG
22   Mechanical seal material AQ1EGG (SU 55)	
D	Scope of supply
	D   Pump with motor
	A   Pump without motor
2	Shaft unit
	2   SU 25
	3   SU 35
	5   SU 55

### Further information on the designation

(⇒ Page 69)

### Design details

#### Design

- Close-coupled design/in-line design
- Single-stage
- Horizontal/vertical installation
- Rigid connection between pump and motor

#### Pump casing

- Radially split volute casing

#### Impeller type

- Closed radial impeller

#### Shaft seal

- Standardised mechanical seal to EN 12756
- Shaft equipped with a replaceable shaft sleeve in the shaft seal area

#### Bearings

- Radial ball bearing in the motor housing

- Grease lubrication

## Drive

Standard design:

- KSB/Siemens surface-cooled IEC three-phase current squirrel-cage motor

Winding	Up to 2.2 kW: 220-240 V/ 380-420 V From 3 kW: 380-420 V/ 660-725 V
Type of construction	Up to 4 kW: IM V1 From 5.5 kW: IM V15
Enclosure	IP55
Thermal class	F
Motor protection	3 PTC thermistors
Efficiency class	IE2 or IE3
Mode of operation	Continuous operation S1

## SuPremE motor (up to 45 kW only):

- KSB SuPremE motor: surface-cooled, IEC-compatible, magnetless synchronous reluctance motor (PumpDrive required)

Frequency	50 Hz/ 60 Hz (at PumpDrive input)
Voltage	380 - 480 V (at PumpDrive input)
Type of construction	IM V15
Enclosure	IP55
Thermal class	F
Motor protection	3 PTC thermistors
Mode of operation	Continuous operation S1
Efficiency class	IE4, as per IEC/CD 60034-30 Ed.2

## Automation

Automation options:

- PumpDrive
- PumpMeter

## Materials

Overview of available materials

Part No.	Description	Material	Material variant		
			G	GB	GC
102	Volute casing	Grey cast iron EN-GJL-250 / A 48 CL 35B	X	X	X
161	Casing cover, conical	Grey cast iron EN-GJL-250 / A 48 CL 35B	X	X	X
210	Shaft	Tempered steel C45+N	X	X	X
		Stainless steel 1.4571 (optional)	X	X	X
230	Impeller	Grey cast iron EN-GJL-250 / A 48 CL 35B	X	-	-
		Bronze CC480K-GS / B30 C90700	-	X	-
		Stainless steel 1.4408 / A743 Gr CF8 M <sup>1)</sup>	-	-	X
341	Drive lantern	Grey cast iron EN-GJL-250 / A 48 CL 35B	X	X	X
400	Sealing elements	DPAF, asbestos-free	X	X	X
502.01	Casing wear ring, suction side	Grey cast iron EN-GJL-250 / A 48 CL 35B	X	X	X
		Bronze CC495K-GS	-	X	-
502.02	Casing wear ring, discharge side	Grey cast iron EN-GJL-250 / A 48 CL 35B	X	X	X
		Bronze CC495K-GS	-	X	-
523	Shaft sleeve	Stainless steel (CrNiMo steel)	X	X	X
902	Studs	Steel 8.8	X	X	X
903	Plug	Steel	X	X	X
920	Nut	8+A2A / 8+B633 SC1 TP3	X	X	X
920.95	Impeller nut	Stainless steel (CrNiMo steel)	X	X	X
		Steel 8	X	X	-

<sup>1)</sup> Size Etaline GC 125-125-250 not available in Europe.

### Coating and preservation

- Coating and preservation to KSB standard

### Product benefits

- Improved efficiency and  $NPSH_{req}$  by experimentally verified hydraulic design of impellers (vanes)
- Low energy costs through compliance with Commission Regulation 547/2012 (minimum efficiency index  $MEI \geq 0.4$ )
- Operating costs reduced by trimming the impeller diameter to match the specified duty point
- Little wear, low vibration levels and excellent smooth running characteristics thanks to good suction performance and virtually cavitation-free operation across a wide operating range
- Casing sealed reliably – even in varying operating conditions – by confined casing gasket
- Large variety of materials for perfectly matching the pump to the fluid handled. Large range of materials for many applications available as standard.
- Low-noise low-vibration motors specially designed for Etaline L. Also available as 2-pole motors.

### Product information as per Regulation No. 547/2012 (for water pumps with a maximum shaft power of 150 kW) implementing "Ecodesign" Directive 2009/125/EC

- Minimum efficiency index: see data sheet
- The benchmark for the most efficient water pumps is  $MEI \geq 0.70$ .
- Year of construction: see data sheet
- Manufacturer's name or trade mark, commercial registration number and place of manufacture: see data sheet or order documentation
- Product's type and size identifier: see data sheet
- Hydraulic pump efficiency (%) with trimmed impeller: see data sheet
- Pump performance curves, including efficiency characteristics: see documented characteristic curve
- The efficiency of a pump with a trimmed impeller is usually lower than that of a pump with full impeller diameter. Trimming of the impeller will adapt the pump to a fixed duty point, leading to reduced energy consumption. The minimum efficiency index (MEI) is based on the full impeller diameter.
- Operation of this water pump with variable duty points may be more efficient and economic when controlled, for example, by the use of a variable speed drive that matches the pump duty to the system.
- Information relevant for disassembly, recycling or disposal at end of life: see installation/operating manual
- Information on benchmark efficiency or benchmark efficiency graph for  $MEI = 0.70$  (0.40) for the pump based on the model shown in the Figure are available at: <http://www.europump.org/efficiencycharts>

### FluidFuture energy efficiency concept developed by KSB



<http://www.ksb.com/fluidfuture>

### Acceptance tests and warranty

The following acceptance tests may be performed at a surcharge:

- **Materials testing**
  - Test report 2.2
- **Final inspection**
  - Inspection certificate 3.1 to EN 10204
- **Hydraulic test**
  - The duty point of each pump is guaranteed according to ISO 9906/2B or ISO 9906/3B.
  - NPSH test
- Other inspections/tests on request

### Warranties

- Warranties are given within the scope of the valid delivery conditions.

**Overview of fluids handled**

Table of fluids handled and associated material combinations

**X** = standard

Fluid handled	Application limit temperature	Casing/impeller materials			Shaft seal Mechanical seal						Comments
		Grey cast iron/ grey cast iron	Grey cast iron/ stainless steel	Grey cast iron/ bronze	U3BEGG (WE 25, 35)	AQ1EGG (WE 55)	Q1Q1EGG	U3U3VGG	Q1Q1X4GG	BQ1EGG	
	[°C]	G	GC	GB	6	22	7	9	10	11	
<b>Water</b>											
Service water	≤ +110	X	-	-	-	-	-	-	X	-	CrNiMo cast steel can be used.
Fire-fighting water <sup>2)</sup>	≤ +60	-	-	X	-	-	-	-	X	-	Contact KSB for supply to VdS guideline.
Heating water <sup>3)</sup>	≤ +110	X	-	-	-	-	-	-	-	X	If used as circulating pump to DIN 4752: p max ≤ 10 bar
Heating water	≤ +140	X	-	-	X	X	-	-	-	-	
Condensate	≤ +110	X	-	-	-	-	-	-	-	X	
Cooling water (without antifreeze)	≤ +60	X	-	-	-	-	-	-	X	-	Open circuit: GB 10 required
Cooling water pH ≥ 7.5 (with antifreeze <sup>4)</sup> )	≥ -30 to +60	X	-	-	-	-	-	-	-	X	Open circuit: GB required
Cooling water pH ≥ 7.5 (with antifreeze <sup>4)</sup> )	≥ +60 to +110	X	-	-	-	-	X	-	-	-	Open circuit: GB required
Slightly contaminated water	≤ +60	X	-	-	-	-	-	-	X	-	
Pure water <sup>5)</sup>	≤ +60	X	-	-	-	-	-	-	-	X	
Raw water	≤ +60	X	-	-	-	-	-	-	X	-	
Swimming pool water (fresh water)	≤ +60	X	-	-	-	-	-	-	X	-	Also applies to requirements as per DIN 19643
Swimming pool water <sup>6)</sup> : filtration	≤ +40	-	-	X	-	-	-	-	X	-	Variant GB: shaft C45+N, shaft sleeve CrNiMo steel, nut A4/AISI 316, key A2, casing wear ring (suction and discharge side) grey cast iron JL 1040/ CI
Swimming pool water <sup>6)</sup> : water features; without turbulences and/or air content	≤ +40	-	-	X	-	-	-	-	X	-	Variant GB: shaft C45+N, shaft sleeve CrNiMo steel, nut A4/AISI 316, key A2, casing wear ring (suction and discharge side) CC495K-GS
Dam water	≤ +60	-	-	X	-	-	-	-	X	-	If solids are contained, contact KSB.
Drinking water <sup>7)</sup>	≤ +60	-	-	X	-	-	-	-	-	X	
Partly desalinated water	≤ +120	X	-	-	-	-	-	-	-	X	
Fully desalinated water as boiler feed water	≤ +110	X	-	-	-	-	-	-	-	X	
<b>Refrigerants, cooling brines</b>											
Cooling brine; inorganic, pH value > 7.5, inhibited	≥ -30 to +25	X	-	-	-	-	-	-	-	X	
Water with antifreeze, pH value ≥ 7.5	≥ -30 to +60	X	-	-	-	-	-	-	-	X	
Water with antifreeze, pH value ≥ 7.5	≥ +60 to +110	X	-	-	-	-	X	-	-	-	
<b>Oils/emulsions</b>											
Drilling emulsion, grinding emulsion	≤ +60	X	-	-	-	-	-	X	-	-	
Oil-water emulsion	≤ +60	X	-	-	-	-	-	X	-	-	

2) General evaluation criteria for results of water analysis: pH value ≥ 7; chlorides content (Cl) ≤ 250 mg/kg. Chlorine (Cl<sub>2</sub>) ≤ 0.6 mg/kg.

3) Treatment to VdTUV 1466; additional requirement: O<sub>2</sub> t < 0.02 mg/l

4) Antifreeze agent on ethylene glycol basis with inhibitors. Content > 20 % to 50 % (e.g. Antifrogen N)

5) No ultra-pure water! Electrical conductivity at 25 °C: ≤ 800 µS/cm, neutral with regard to chemical corrosion

6) For France, observe the applicable rules as per ministerial order dated 18 January 2002.

7) For France, ACS approval is required.

**Pressure limits and temperature limits**

Pressure limits and temperature limits as a function of material variant

Material variant	Fluid temperature <sup>8)9)</sup>	Test pressure <sup>10)</sup>
	[°C]	[bar]
G, GB, GC	-30 to +140	≤ 21

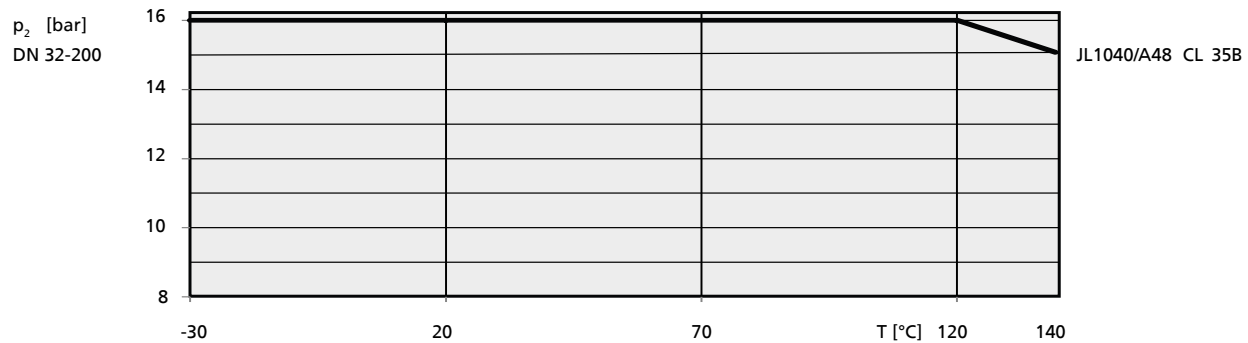

In-service pressure limits and temperature limits

**Technical data**
**Technical data of the motor**

n = 2900 rpm

Size	Motor			[kg]
	Size	[kW]	400 V [A]	
032-032-160	80M	1,10	2,41	35.14
032-032-160	90S	1,50	3,15	38.17
032-032-160	90L	2,20	4,46	40.97
032-032-160	100L	3,00	6,09	47.61
032-032-160	112M	4,00	7,82	51.61
032-032-160	132S	5,50	10,49	72.02
032-032-160	132S	7,50	14,12	79.02
032-032-200	100L	3,00	6,09	56.74
032-032-200	112M	4,00	7,82	60.74
032-032-200	132S	5,50	10,49	81.15
032-032-200	132S	7,50	14,12	88.15
032-032-200	160M	11,00	20,41	114.36
032-032-200	160M	15,00	27,25	125.36
040-040-160	90L	2,20	4,46	41.49
040-040-160	100L	3,00	6,09	48.13
040-040-160	112M	4,00	7,82	52.13
040-040-160	132S	5,50	10,49	72.54
040-040-160	132S	7,50	14,12	79.54
040-040-160	160M	11,00	20,41	105.75
040-040-250	132S	5,50	10,49	87.9
040-040-250	132S	7,50	14,12	94.9
040-040-250	160M	11,00	20,41	121.11
040-040-250	160M	15,00	27,25	132.11
040-040-250	160L	18,50	33,38	149.11
040-040-250	180M	22,00	39,52	214.74
040-040-250	200L	30,00	54,73	284.23

Size	Motor			[kg]
	Size	[kW]	400 V [A]	
040-040-250	200L	37,00	66,36	304.23
050-050-160	90L	2,20	4,46	45.78
050-050-160	100L	3,00	6,09	52.42
050-050-160	112M	4,00	7,82	56.42
050-050-160	132S	5,50	10,49	76.83
050-050-160	132S	7,50	14,12	83.83
050-050-160	160M	11,00	20,41	110.04
050-050-160	160M	15,00	27,25	121.04
050-050-250	132S	7,50	14,12	97.93
050-050-250	160M	11,00	20,41	124.14
050-050-250	160M	15,00	27,25	135.14
050-050-250	160L	18,50	33,38	152.14
050-050-250	180M	22,00	39,52	217.77
050-050-250	200L	30,00	54,73	287.26
050-050-250	200L	37,00	66,36	307.26
065-065-160	100L	3,00	6,09	54.67
065-065-160	112M	4,00	7,82	58.67
065-065-160	132S	5,50	10,49	79.08
065-065-160	132S	7,50	14,12	86.08
065-065-160	160M	11,00	20,41	112.29
065-065-160	160M	15,00	27,25	123.29
065-065-160	160L	18,50	33,38	140.29
065-065-160	180M	22,00	39,52	205.92
065-065-250	160M	11,00	20,41	128.21
065-065-250	160M	15,00	27,25	139.21
065-065-250	160L	18,50	33,38	156.21
065-065-250	180M	22,00	39,52	221.84
065-065-250	200L	30,00	54,73	291.33
065-065-250	200L	37,00	66,36	311.33
080-080-160	132S	5,50	10,49	85.12
080-080-160	132S	7,50	14,12	92.12
080-080-160	160M	11,00	20,41	118.33

8) For hot water heating systems to DIN 4752, Section 4.5, application limits must be observed.

9) For fluid temperatures &gt;140 °C use Etanorm SYT.

10) The casing components are checked for leakage by means of internal pressure tests to AN 1897/75-03D00 with water.



Size	Motor			[kg]
	Size	[kW]	400 V [A]	
080-080-160	160M	15,00	27,25	129.33
080-080-160	160L	18,50	33,38	146.33
080-080-160	180M	22,00	39,52	211.96
080-080-160	200L	30,00	54,73	281.45
080-080-200	160M	11,00	20,41	127.11
080-080-200	160M	15,00	27,25	138.11
080-080-200	160L	18,50	33,38	155.11
080-080-200	180M	22,00	39,52	220.74
080-080-200	200L	30,00	54,73	290.23
080-080-200	200L	37,00	66,36	310.23
100-100-125	132S	5,50	10,49	90.06
100-100-125	132S	7,50	14,12	97.06
100-100-125	160M	11,00	20,41	123.27
100-100-125	160M	15,00	27,25	134.27
100-100-160	160M	11,00	20,41	129.85
100-100-160	160M	15,00	27,25	140.85
100-100-160	160L	18,50	33,38	157.85
100-100-160	180M	22,00	39,52	223.48
100-100-160	200L	30,00	54,73	292.97
100-100-160	200L	37,00	66,36	312.97
125-125-160	160L	18,50	33,38	212.48
125-125-160	180M	22,00	39,52	278.1
125-125-160	200L	30,00	54,73	347.39
125-125-160	200L	37,00	66,36	367.39
125-125-160	225M	45,00	79,45	433.64
125-125-200	180M	22,00	39,52	275.19
125-125-200	200L	30,00	54,73	344.48
125-125-200	200L	37,00	66,36	364.48
125-125-200	225M	45,00	79,45	430.73

n = 1450 rpm

Size	Motor			[kg]
	Size	[kW]	400 V [A]	
032-032-160	71M	0,25	0,77	28.68
032-032-160	71M	0,37	1,06	29.88
032-032-160	80M	0,55	1,46	33.24
032-032-160	80M	0,75	1,67	34.64
032-032-160	90S	1,10	2,51	37.57
032-032-200	71M	0,37	1,06	39.01
032-032-200	80M	0,55	1,46	42.37
032-032-200	80M	0,75	1,67	43.77
032-032-200	90S	1,10	2,51	46.7
032-032-200	90L	1,50	3,32	50
032-032-200	100L	2,20	4,67	57.74
040-040-160	71M	0,37	1,06	30.4
040-040-160	80M	0,55	1,46	33.76
040-040-160	80M	0,75	1,67	35.16
040-040-160	90S	1,10	2,51	38.09
040-040-160	90L	1,50	3,32	41.39
040-040-250	80M	0,75	1,67	50.52
040-040-250	90S	1,10	2,51	53.45
040-040-250	90L	1,50	3,32	56.75
040-040-250	100L	2,20	4,67	64.49
040-040-250	100L	3,00	6,18	66.49
040-040-250	112M	4,00	8,23	71.49
040-040-250	132S	5,50	11,32	83.9

Size	Motor			[kg]
	Size	[kW]	400 V [A]	
050-050-160	71M	0,37	1,06	34.69
050-050-160	80M	0,55	1,46	38.05
050-050-160	80M	0,75	1,67	39.45
050-050-160	90S	1,10	2,51	42.38
050-050-160	90L	1,50	3,32	45.68
050-050-160	100L	2,20	4,67	53.42
050-050-250	90S	1,10	2,51	56.48
050-050-250	90L	1,50	3,32	59.78
050-050-250	100L	2,20	4,67	67.52
050-050-250	100L	3,00	6,18	69.52
050-050-250	112M	4,00	8,23	74.52
050-050-250	132S	5,50	11,32	86.93
050-050-250	132M	7,50	14,70	100.93
065-065-160	71M	0,37	1,06	36.94
065-065-160	80M	0,55	1,46	40.3
065-065-160	80M	0,75	1,67	41.7
065-065-160	90S	1,10	2,51	44.63
065-065-160	90L	1,50	3,32	47.93
065-065-160	100L	2,20	4,67	55.67
065-065-160	100L	3,00	6,18	57.67
065-065-250	90L	1,50	3,32	63.85
065-065-250	100L	2,20	4,67	71.59
065-065-250	100L	3,00	6,18	73.59
065-065-250	112M	4,00	8,23	78.59
065-065-250	132S	5,50	11,32	91
065-065-250	132M	7,50	14,70	105
065-065-250	160M	11,00	20,80	131.21
080-080-160	80M	0,55	1,46	46.34
080-080-160	80M	0,75	1,67	47.74
080-080-160	90S	1,10	2,51	50.67
080-080-160	90L	1,50	3,32	53.97
080-080-160	100L	2,20	4,67	61.71
080-080-160	100L	3,00	6,18	63.71
080-080-160	112M	4,00	8,23	68.71
080-080-200	90S	1,10	2,51	59.45
080-080-200	90L	1,50	3,32	62.75
080-080-200	100L	2,20	4,67	70.49
080-080-200	100L	3,00	6,18	72.49
080-080-200	112M	4,00	8,23	77.49
080-080-200	132S	5,50	11,32	89.9
080-080-200	132M	7,50	14,70	103.9
080-080-250	100L	2,20	4,67	90.79
080-080-250	100L	3,00	6,18	92.79
080-080-250	112M	4,00	8,23	97.79
080-080-250	132S	5,50	11,32	109.69
080-080-250	132M	7,50	14,70	123.69
080-080-250	160M	11,00	20,80	149.9
080-080-250	160L	15,00	28,11	165.9
100-100-125	80M	0,75	1,67	52.68
100-100-125	90S	1,10	2,51	55.61
100-100-125	90L	1,50	3,32	58.91
100-100-125	100L	2,20	4,67	66.65
100-100-160	90L	1,50	3,32	65.49
100-100-160	100L	2,20	4,67	73.23
100-100-160	100L	3,00	6,18	75.23
100-100-160	112M	4,00	8,23	80.23
100-100-160	132S	5,50	11,32	92.64
100-100-200	100L	2,20	4,67	105.64

Size	Motor			[kg]
	Size	[kW]	400 V [A]	
100-100-200	100L	3,00	6,18	107.64
100-100-200	112M	4,00	8,23	112.64
100-100-200	132S	5,50	11,32	124.54
100-100-200	132M	7,50	14,70	138.54
100-100-200	160M	11,00	20,80	164.75
100-100-250	100L	3,00	6,18	119.56
100-100-250	112M	4,00	8,23	124.56
100-100-250	132S	5,50	11,32	136.46
100-100-250	132M	7,50	14,70	150.46
100-100-250	160M	11,00	20,80	176.67
100-100-250	160L	15,00	28,11	192.67
100-100-250	180M	18,50	35,28	267.29
125-125-160	100L	2,20	4,67	128.37
125-125-160	100L	3,00	6,18	130.37
125-125-160	112M	4,00	8,23	135.37
125-125-160	132S	5,50	11,32	147.27
125-125-160	132M	7,50	14,70	161.27
125-125-200	100L	3,00	6,18	127.46
125-125-200	112M	4,00	8,23	132.46
125-125-200	132S	5,50	11,32	144.36
125-125-200	132M	7,50	14,70	158.36
125-125-200	160M	11,00	20,80	184.57
125-125-200	160L	15,00	28,11	200.57
125-125-250	132S	5,50	11,32	156.47
125-125-250	132M	7,50	14,70	170.47
125-125-250	160M	11,00	20,80	196.68
125-125-250	160L	15,00	28,11	212.68
125-125-250	180M	18,50	35,28	287.3
125-125-250	180L	22,00	41,27	302.3
150-150-200	132S	5,50	11,32	175.85
150-150-200	132M	7,50	14,70	189.85
150-150-200	160M	11,00	20,80	216.06
150-150-200	160L	15,00	28,11	232.06
150-150-200	180M	18,50	35,28	306.68
150-150-250	132M	7,50	14,70	204.14
150-150-250	160M	11,00	20,80	230.35
150-150-250	160L	15,00	28,11	246.35
150-150-250	180M	18,50	35,28	320.97
150-150-250	180L	22,00	41,27	335.97
150-150-250	200L	30,00	55,19	400.26
150-150-250	225S	37,00	65,47	466.65
200-200-250	160M	11,00	20,80	285.87
200-200-250	160L	15,00	28,11	301.87
200-200-250	180M	18,50	35,28	376.49
200-200-250	180L	22,00	41,27	391.49
200-200-250	200L	30,00	55,19	455.78
200-200-250	225S	37,00	65,47	522.17
200-200-250	225M	45,00	80,19	552.17
200-200-315	180L	22,00	41,27	430.01
200-200-315	200L	30,00	55,19	490.01
200-200-315	225S	37,00	65,47	556.25
200-200-315	225M	45,00	80,19	586.25
200-200-315	250M	55,00	99,89	699.62

**Technical data of the pump**

## Overview

Size	Shaft unit	Impeller				Speed limit	
		Impeller outlet width	Impeller inlet diameter	Impeller diameter		Minimum	Maximum
				Minimum	Maximum		
[mm]	[mm]	[mm]	[mm]	[rpm]	[rpm]		
032-032-160	WS_25	5,7	52,7	112	170	500	4400
032-032-200	WS_25	5,6	54,0	165	204	500	3800
040-040-160	WS_25	8,5	60,6	136	174	500	3500
040-040-250	WS_25	7,5	62,6	197	261	500	3000
050-050-160	WS_25	13,0	70,0	120	174	500	4400
050-050-250	WS_25	8,4	74,1	198	260	500	3000
065-065-160	WS_25	16,9	86,9	108	174	500	4400
065-065-250	WS_25	10,5	84,0	196	260	500	3000
080-080-160	WS_25	21,0	92,0	132	174	500	3900
080-080-200	WS_25	17,0	99,7	170	219	500	3000
080-080-250	WS_35	15,1	101,0	190	260	500	3000
100-100-125	WS_25	25,8	99,0	124	141	500	4000
100-100-160	WS_25	31,6	124,0	138	174	500	3500
100-100-200	WS_35	24,5	115,0	178	219	500	3500
100-100-250	WS_35	19,0	115,0	215	269	500	2900
125-125-160	WS_35	37,6	135,0	155	185	500	3600
125-125-200	WS_35	32,5	142,0	179	219	500	3300
125-125-250	WS_35	27,0	145,0	210	269	500	2500
150-150-200	WS_35	40,7	159,0	178	224	500	2600
150-150-250	WS_35	37,0	162,4	218	269	500	2000
200-200-250	WS_35	48,8	191,0	220	269	500	1800
200-200-315	WS_55	39,7	191,5	264	334	500	2100

Selection charts

Etaline, n = 2900 rpm

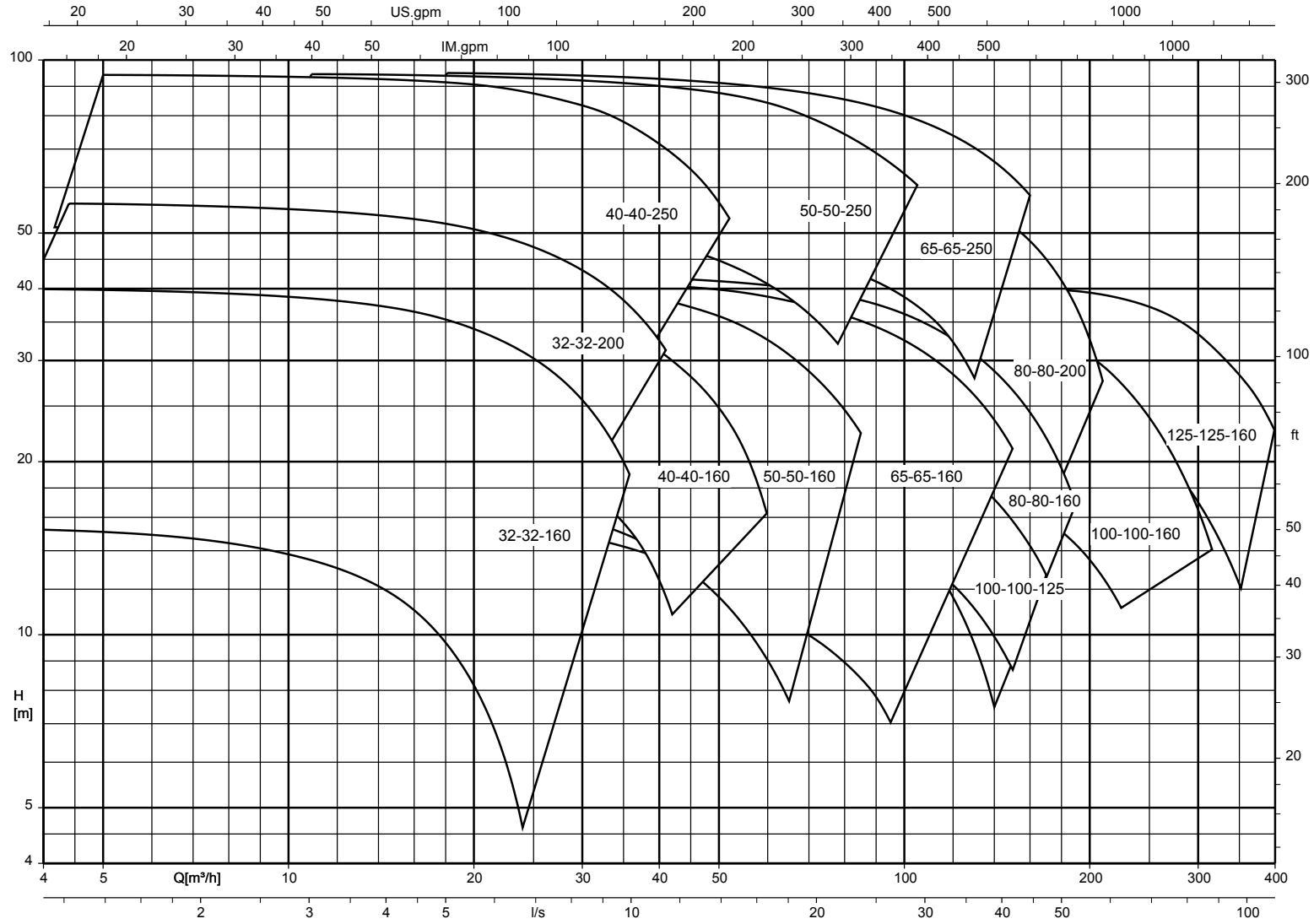

Etaline, n = 1450 rpm

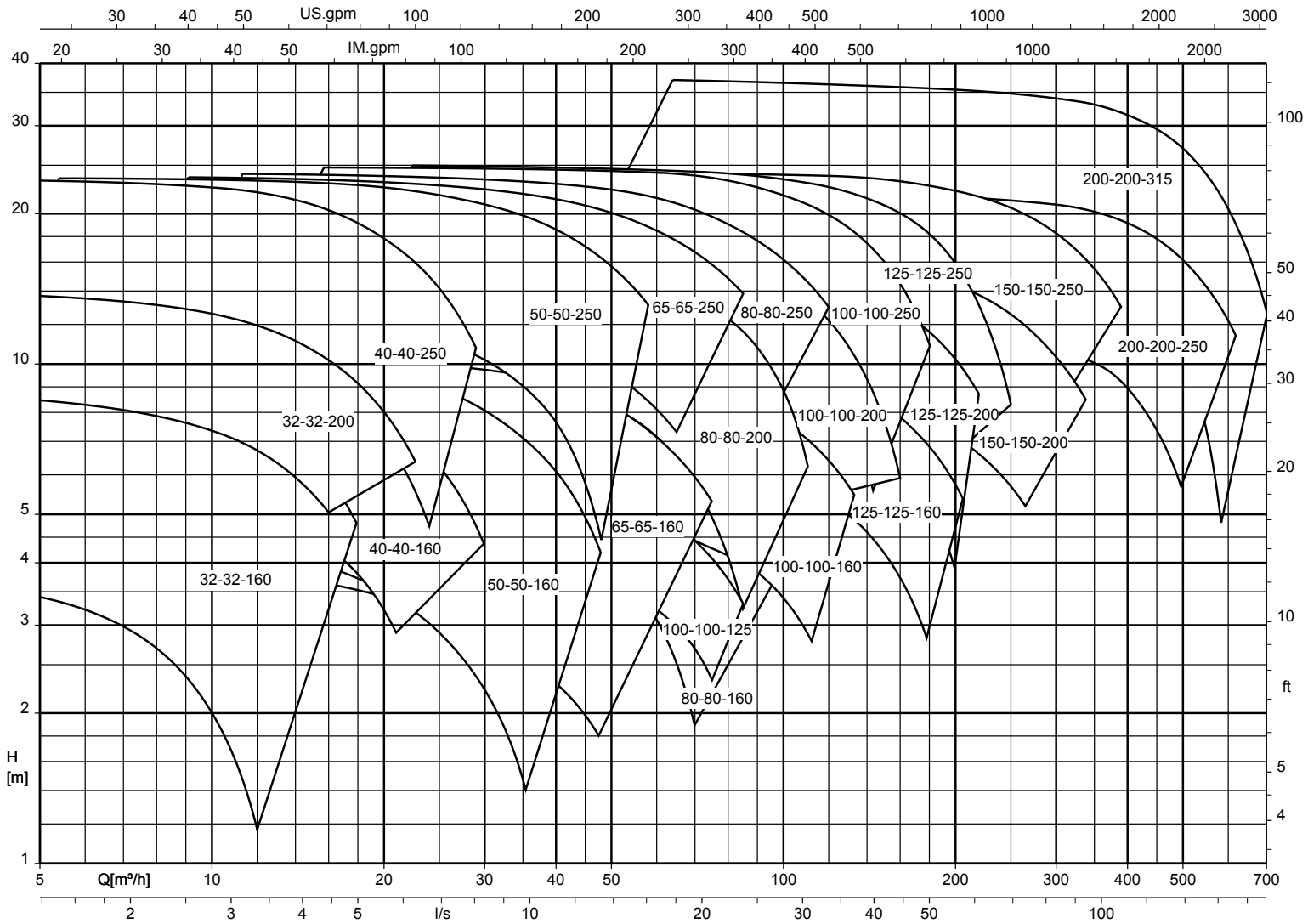

## Characteristic curves

### General

#### Test class

Characteristic curves to ISO 9906 Class 3B

#### NPSH values

The NPSH values indicated in the characteristic curves correspond to a head drop of 3 %.

#### NPSH values in low-flow conditions

NPSH values for flow rates below  $Q = 0.3 \times Q_{opt}$  can only be measured with intense technical efforts. Evidence of NPSH values in the low-flow range cannot be provided.

#### Density of the fluid handled

The indicated heads and performance data apply to pumped fluids with a density  $\rho = 1.0 \text{ kg/dm}^3$  and a kinematic viscosity of up to  $20 \text{ mm}^2/\text{s}$  max. If the density  $\neq 1.0$ , the performance data must be multiplied by  $\rho$ . For viscosities  $>20 \text{ mm}^2/\text{s}$  the corresponding data for cold water has to be calculated and the impact on the pump's performance has to be determined.

#### Correction factors

The characteristic curves apply to pumps with cast iron or bronze impellers. When using an impeller made of cast steel materials the efficiency and pump power of the corresponding pump sizes have to be multiplied by the correction factors indicated in the characteristic curves.

Etaline, n = 2900 rpm

Etaline 032-032-160, n = 2900 rpm

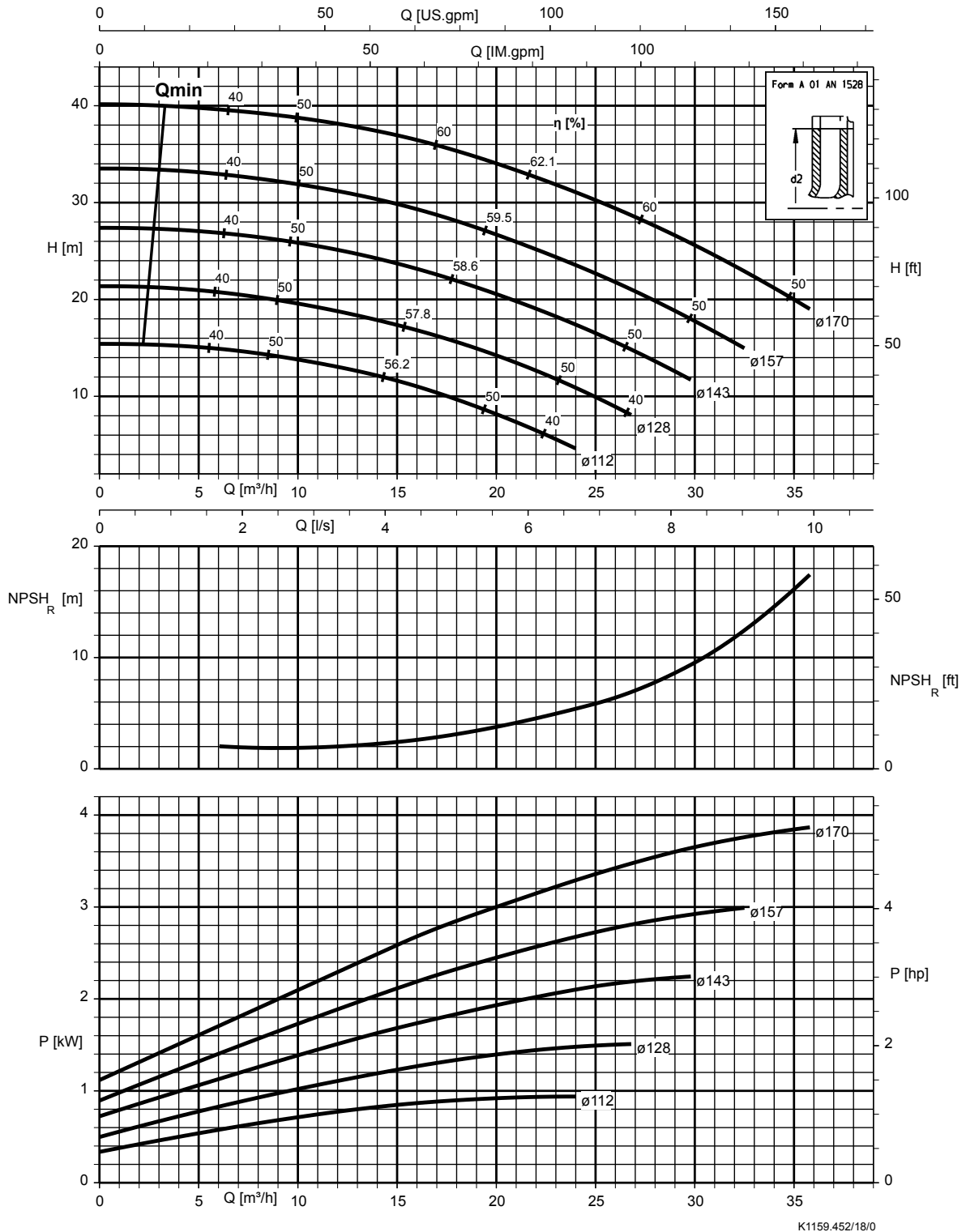

**Etaline 032-032-200, n = 2900 rpm**

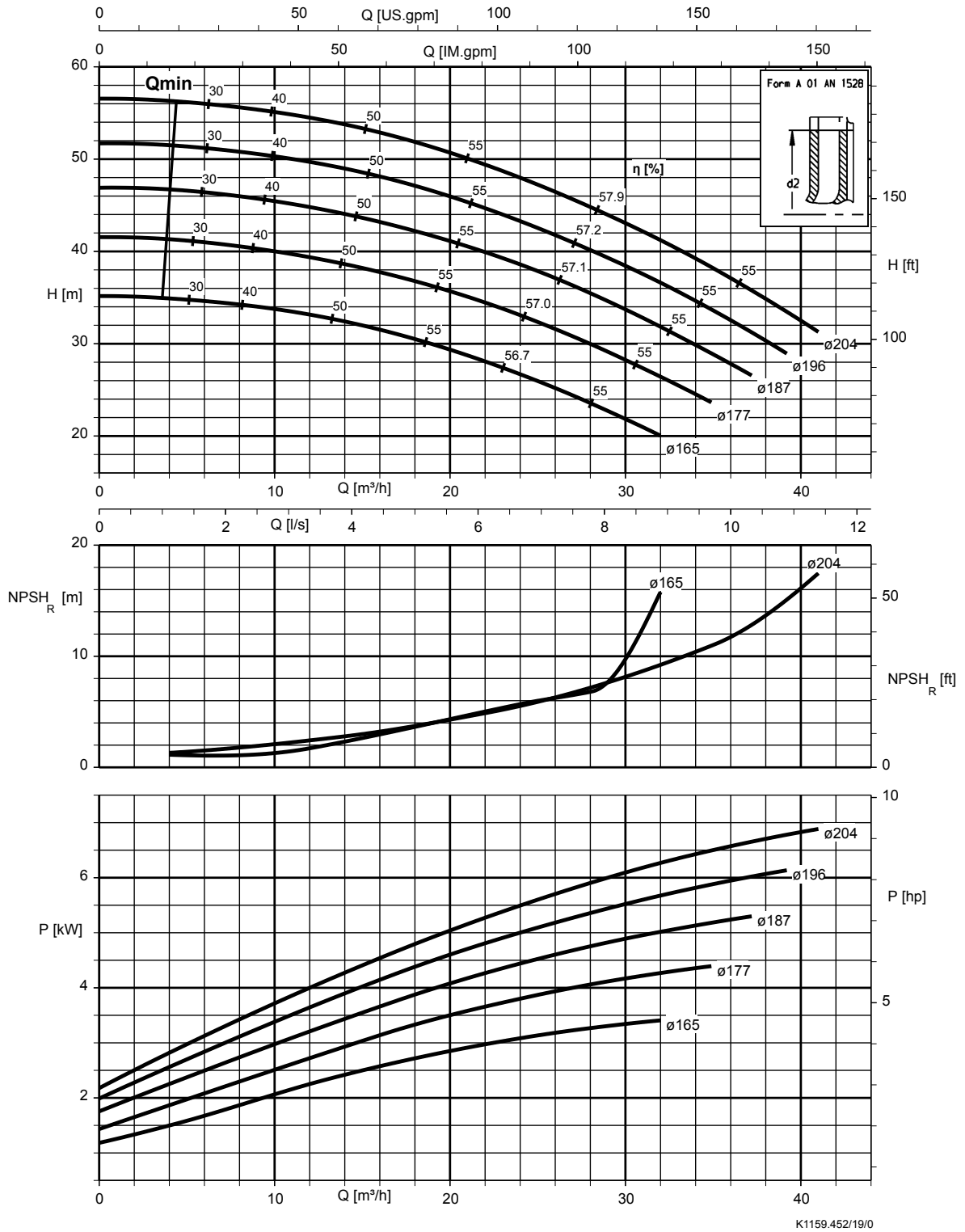



**Etaline 040-040-160, n = 2900 rpm**

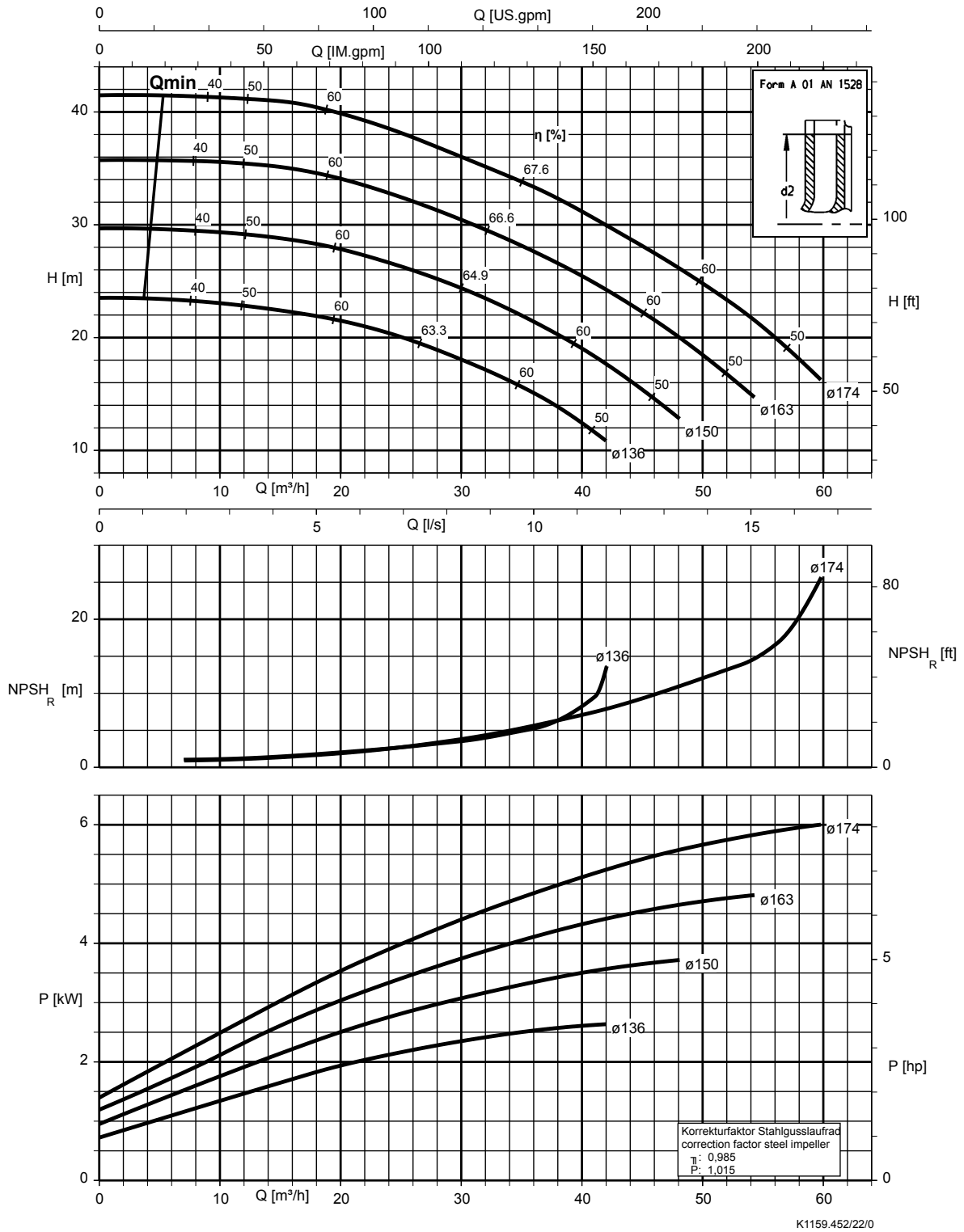

Etaline 040-040-250, n = 2900 rpm

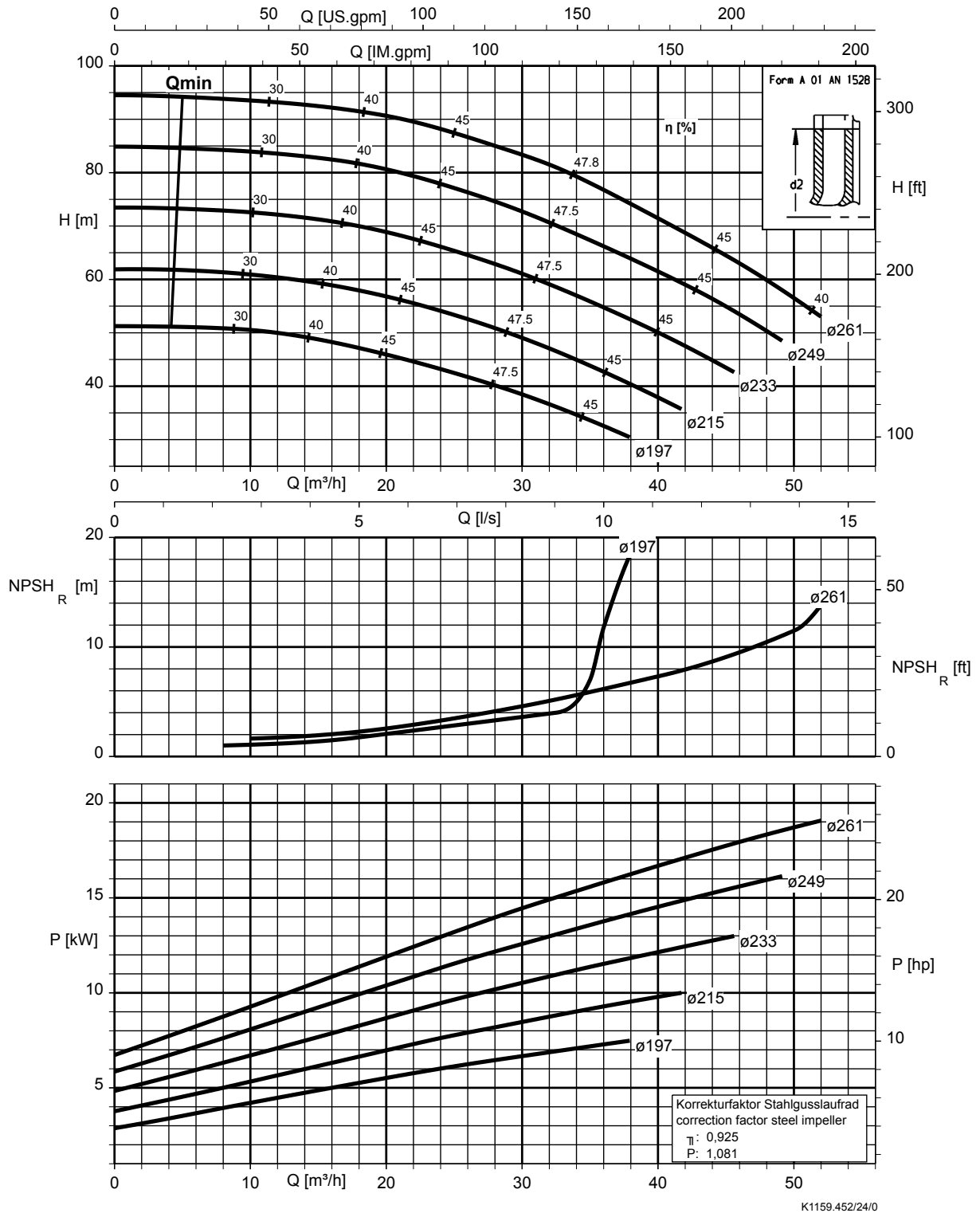

Etaline 050-050-160, n = 2900 rpm

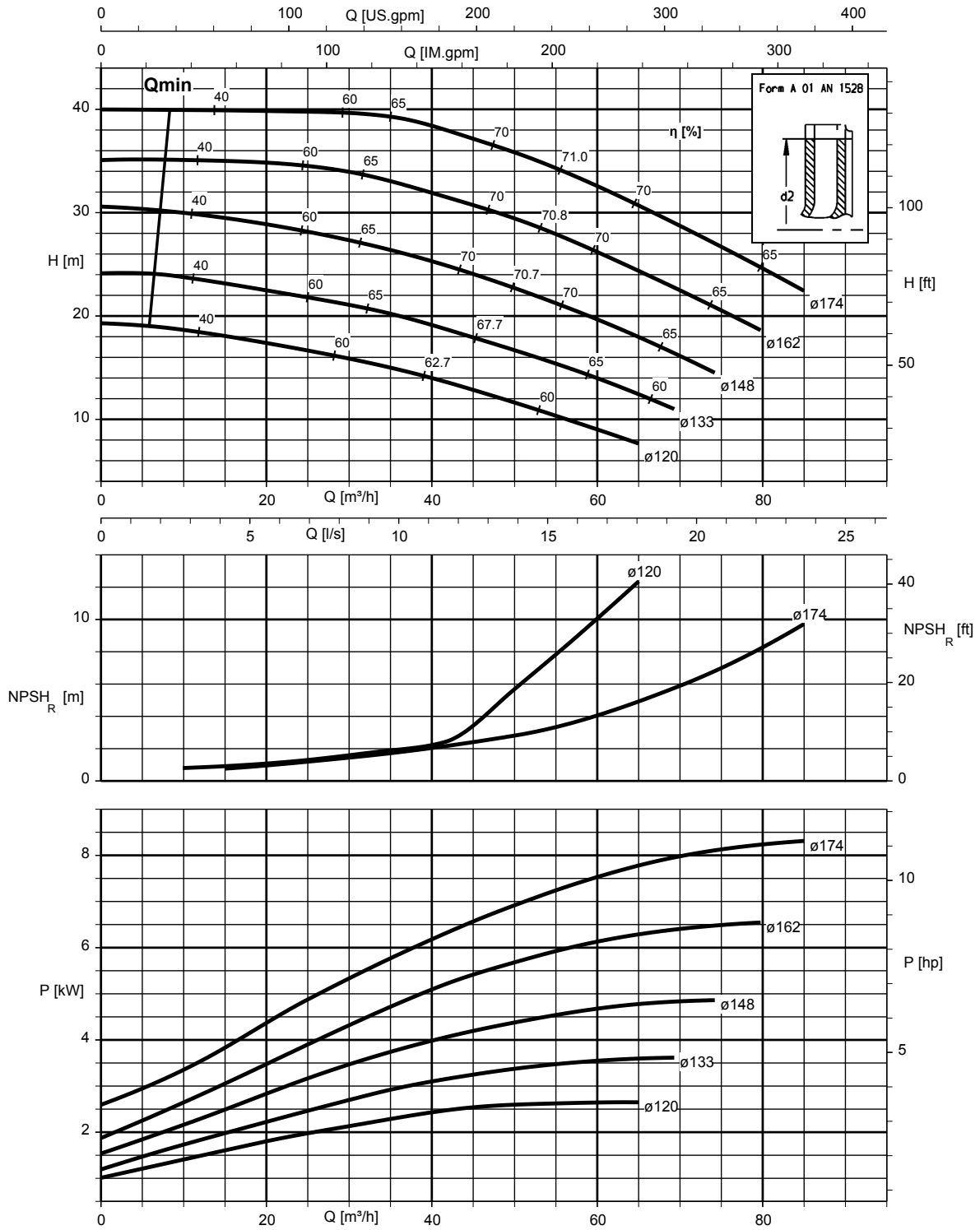

K1159.452/26/0

Etaline 050-050-250, n = 2900 rpm

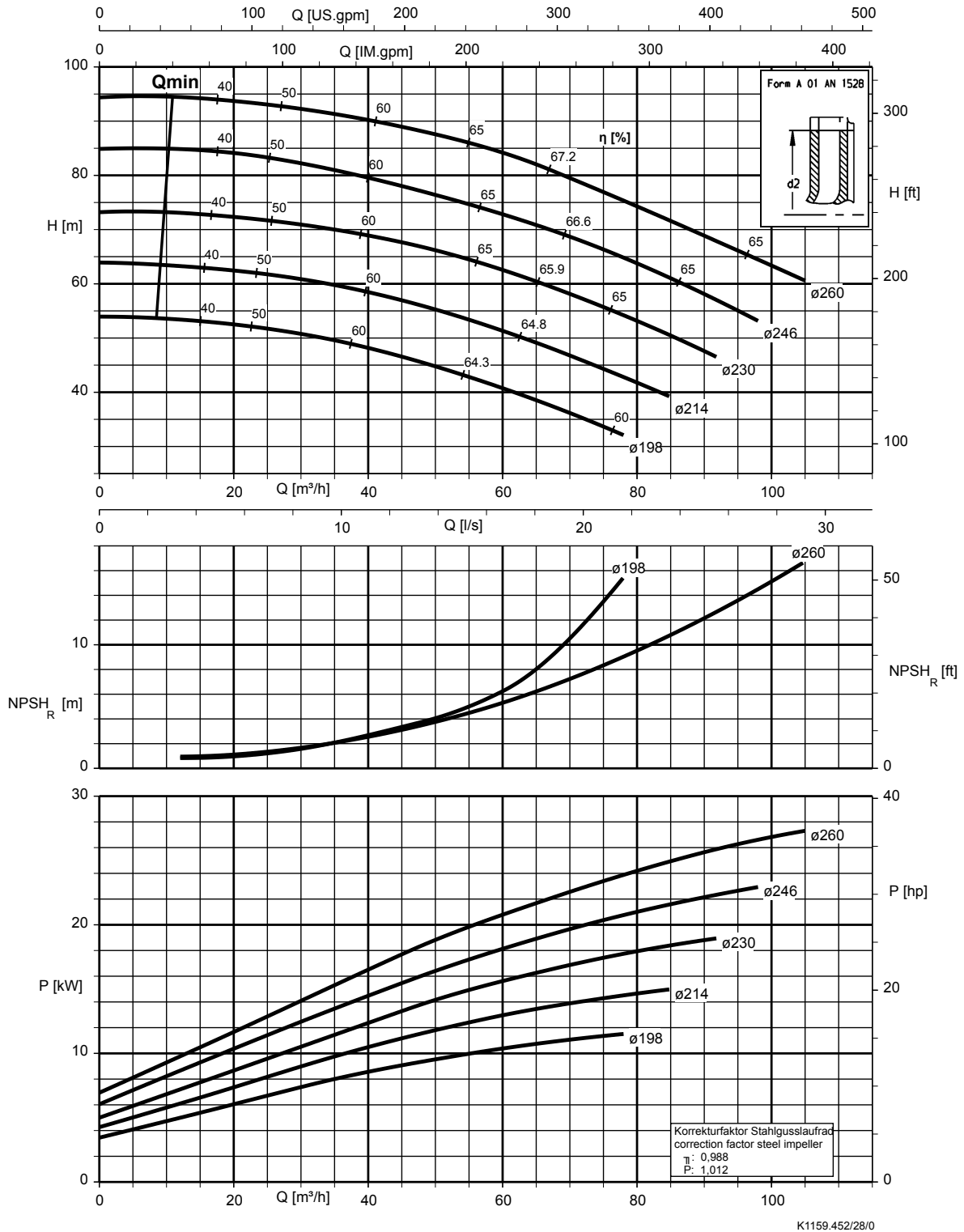

Etaline 065-065-160, n = 2900 rpm

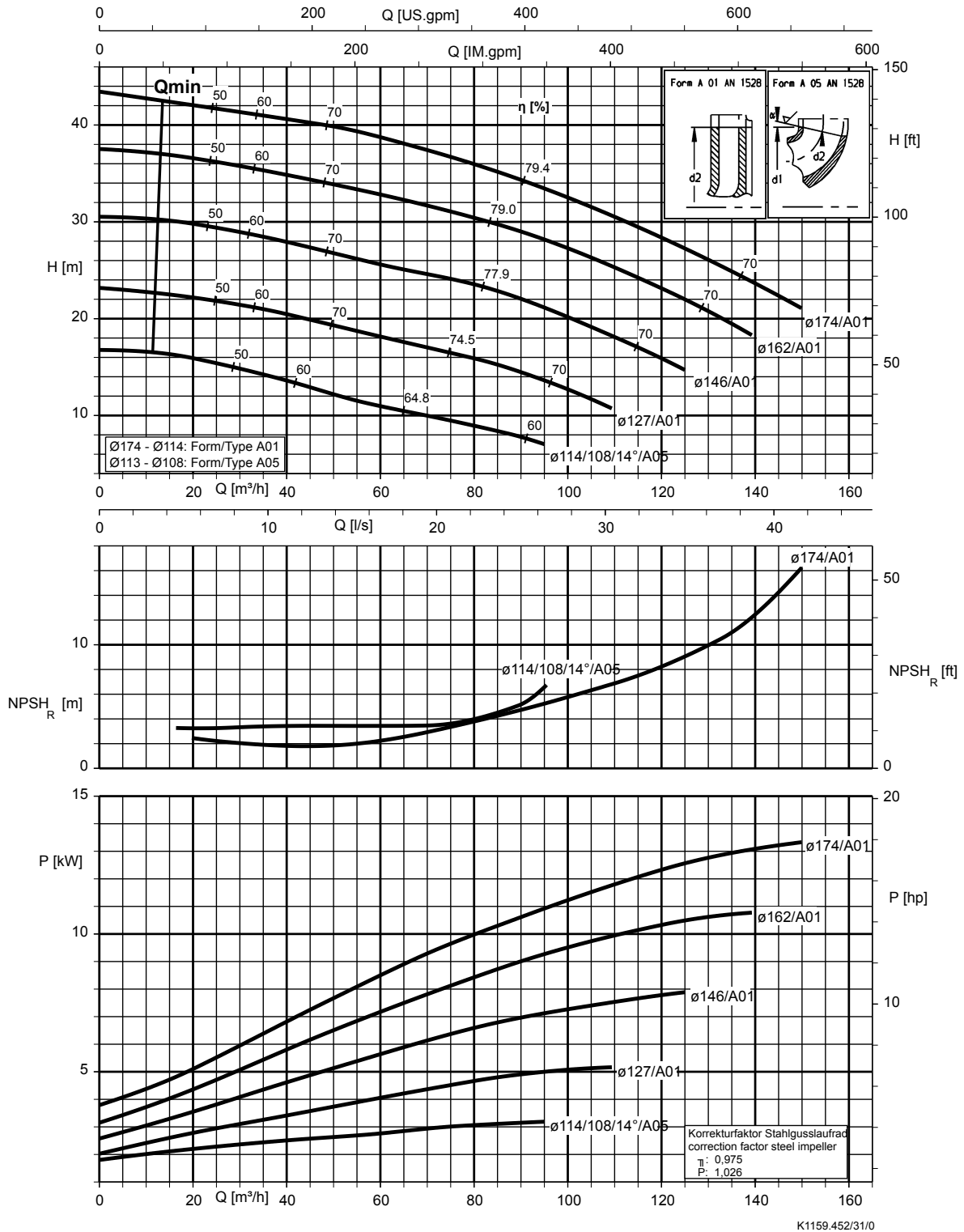

Etaline 065-065-250, n = 2900 rpm

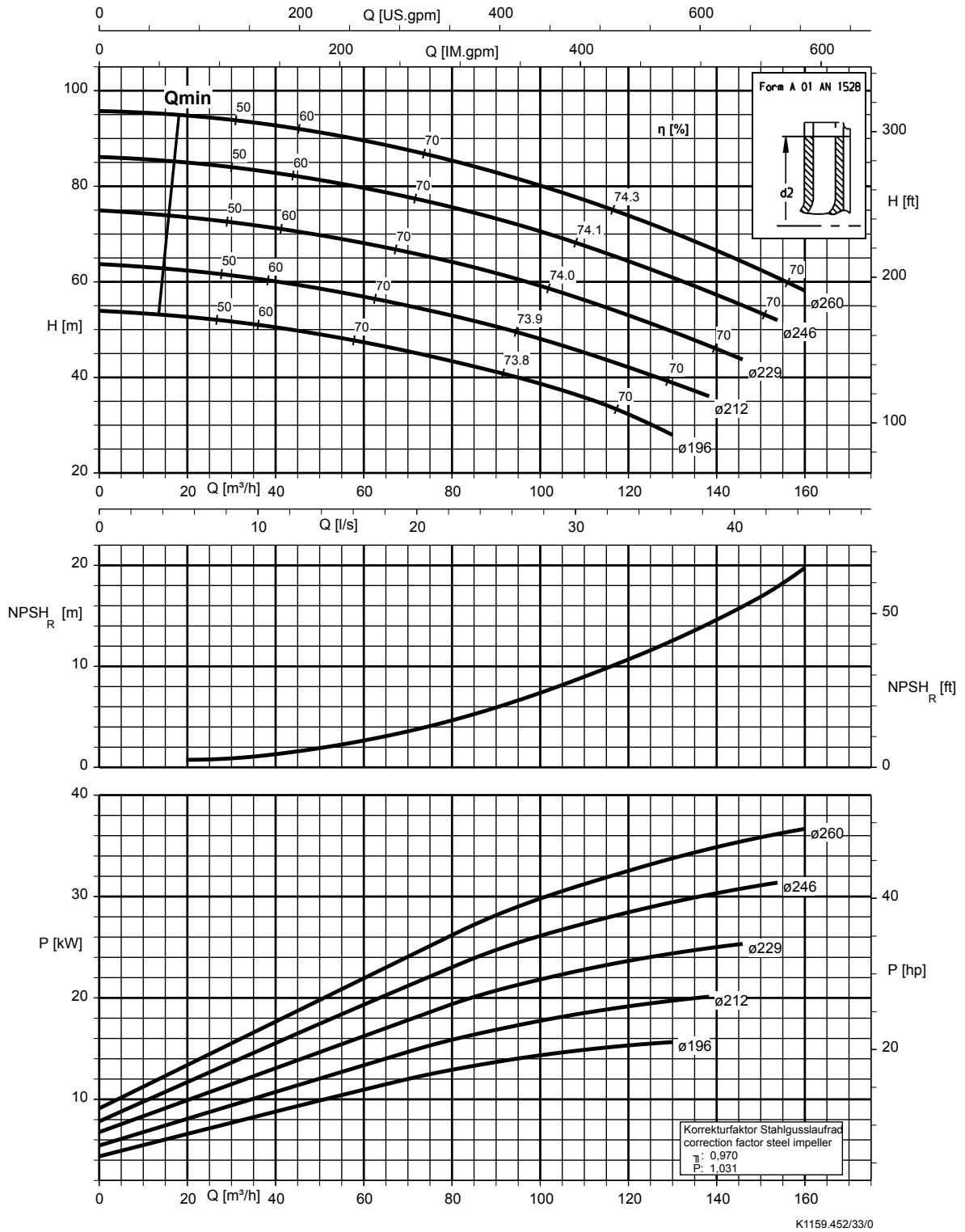

Etaline 080-080-160, n = 2900 rpm

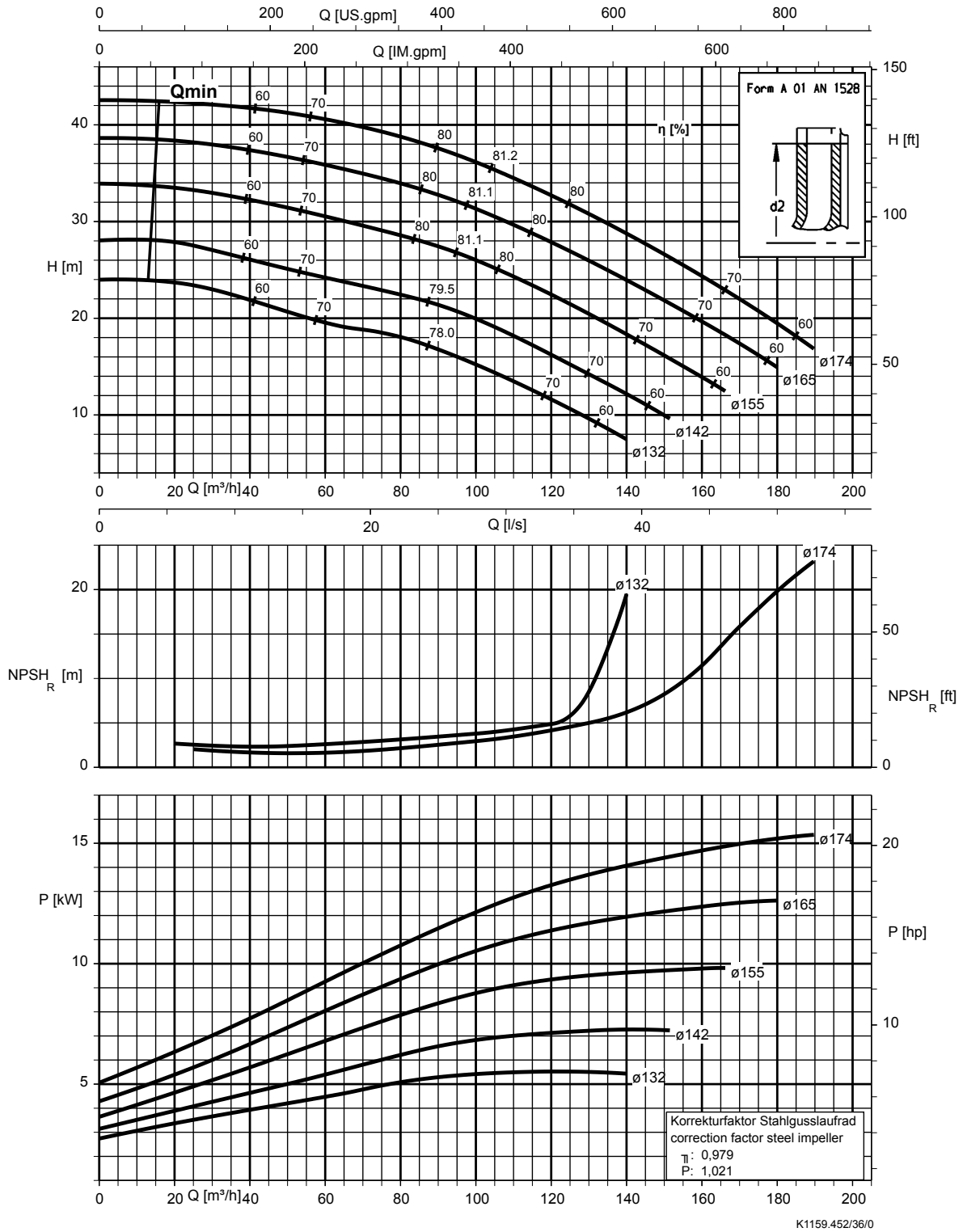

Etaline 080-080-200, n = 2900 rpm

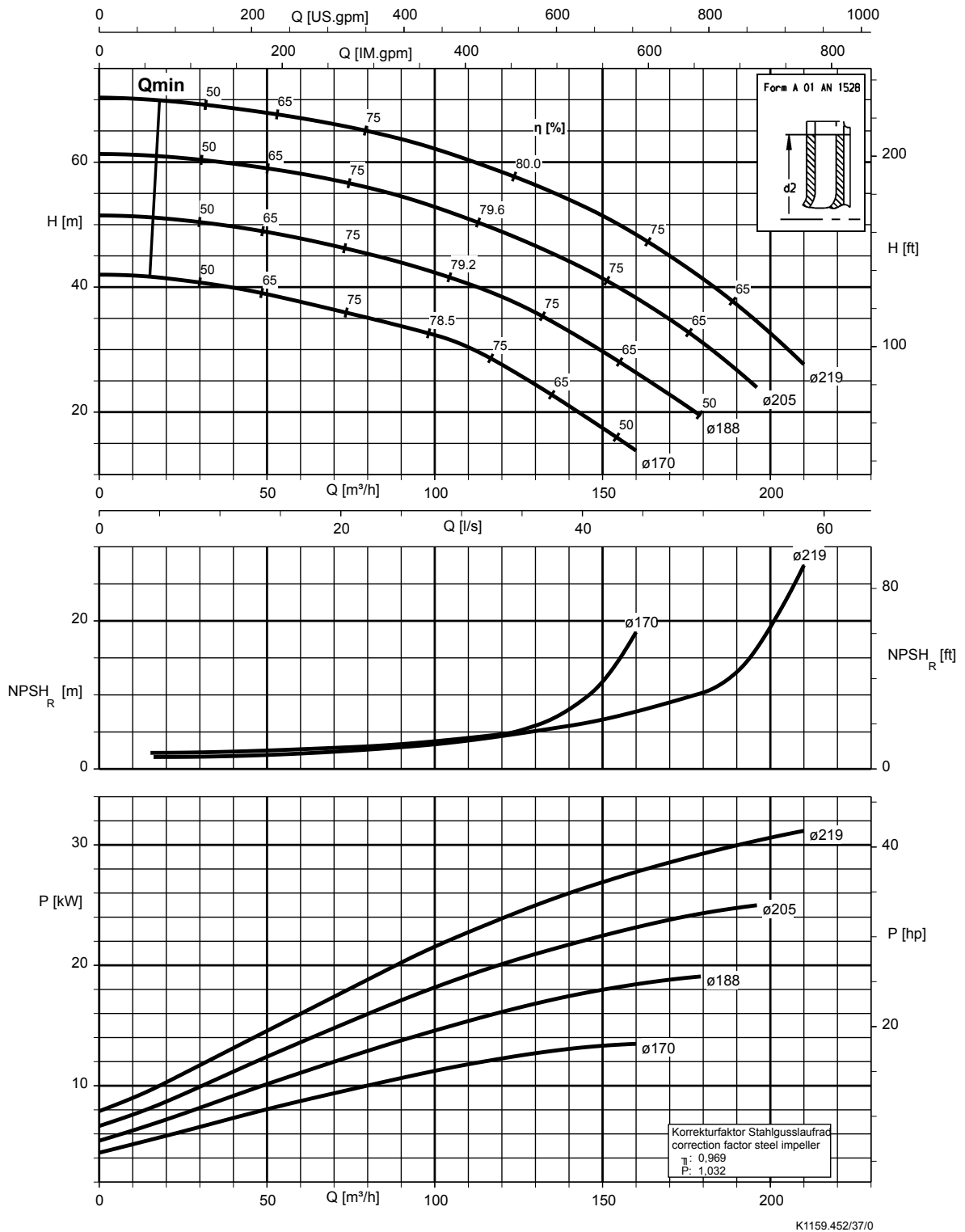



Etaline 100-100-125, n = 2900 rpm

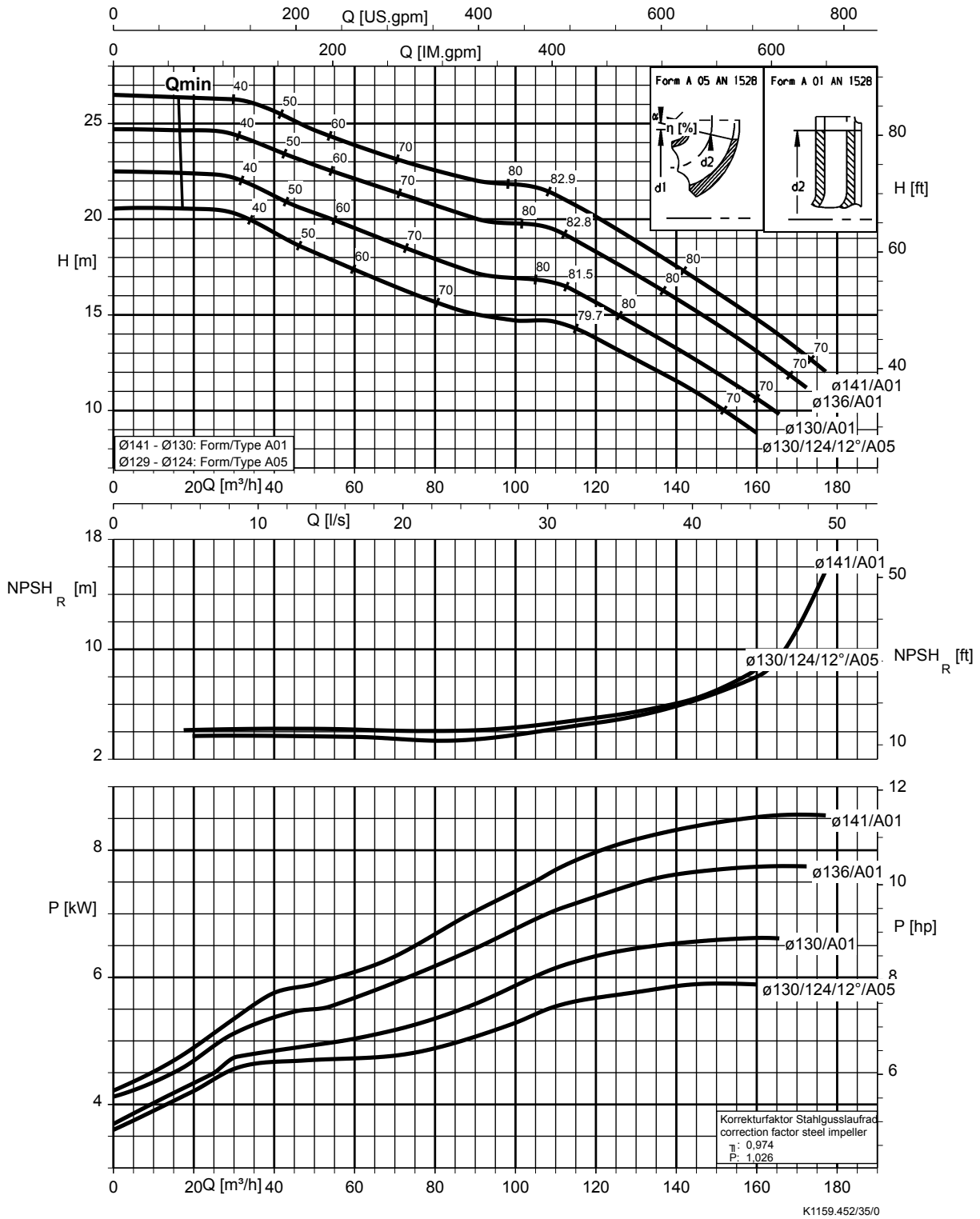

**Etaline 100-100-160, n = 2900 rpm**

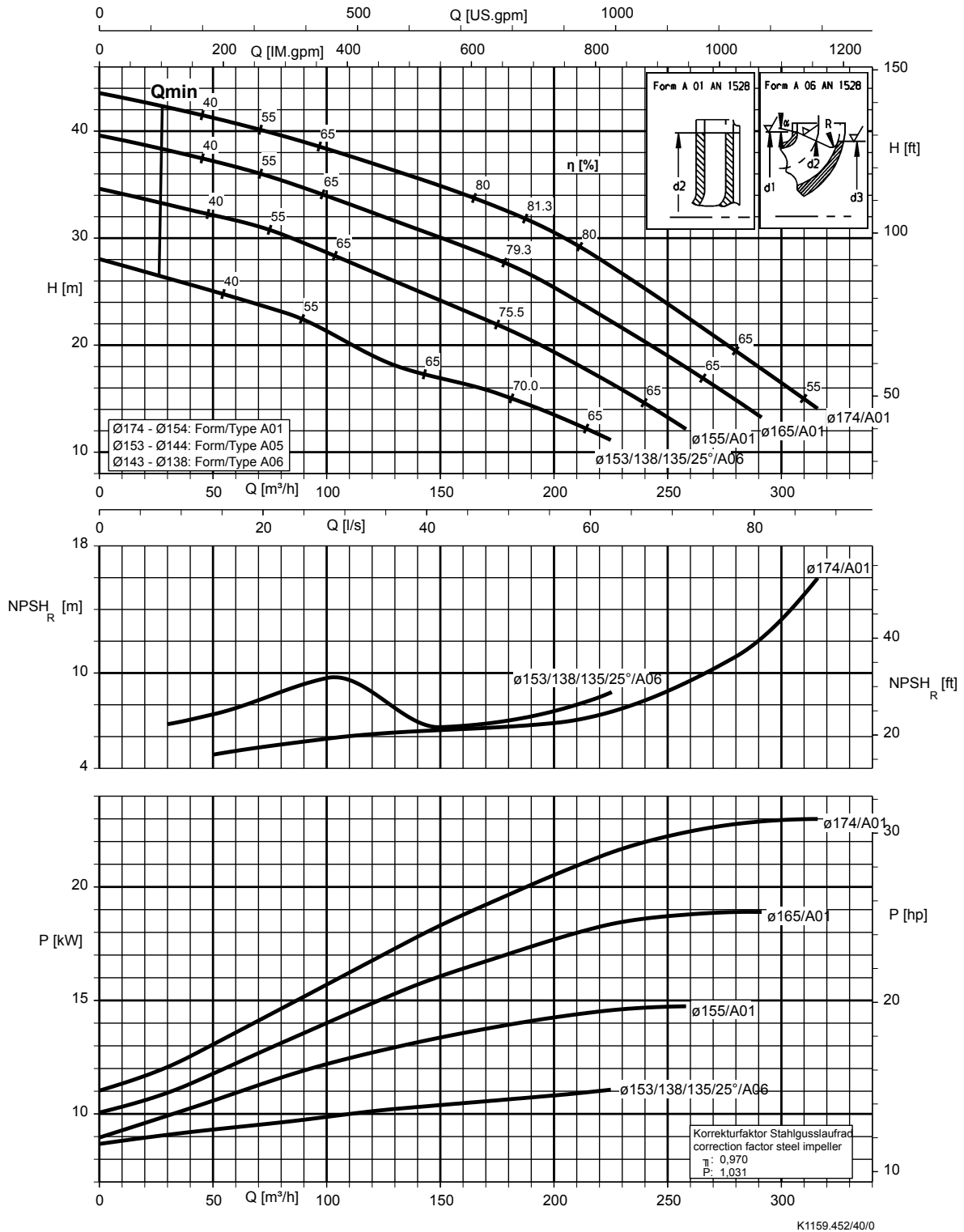

Etaline 125-125-160, n = 2900 rpm

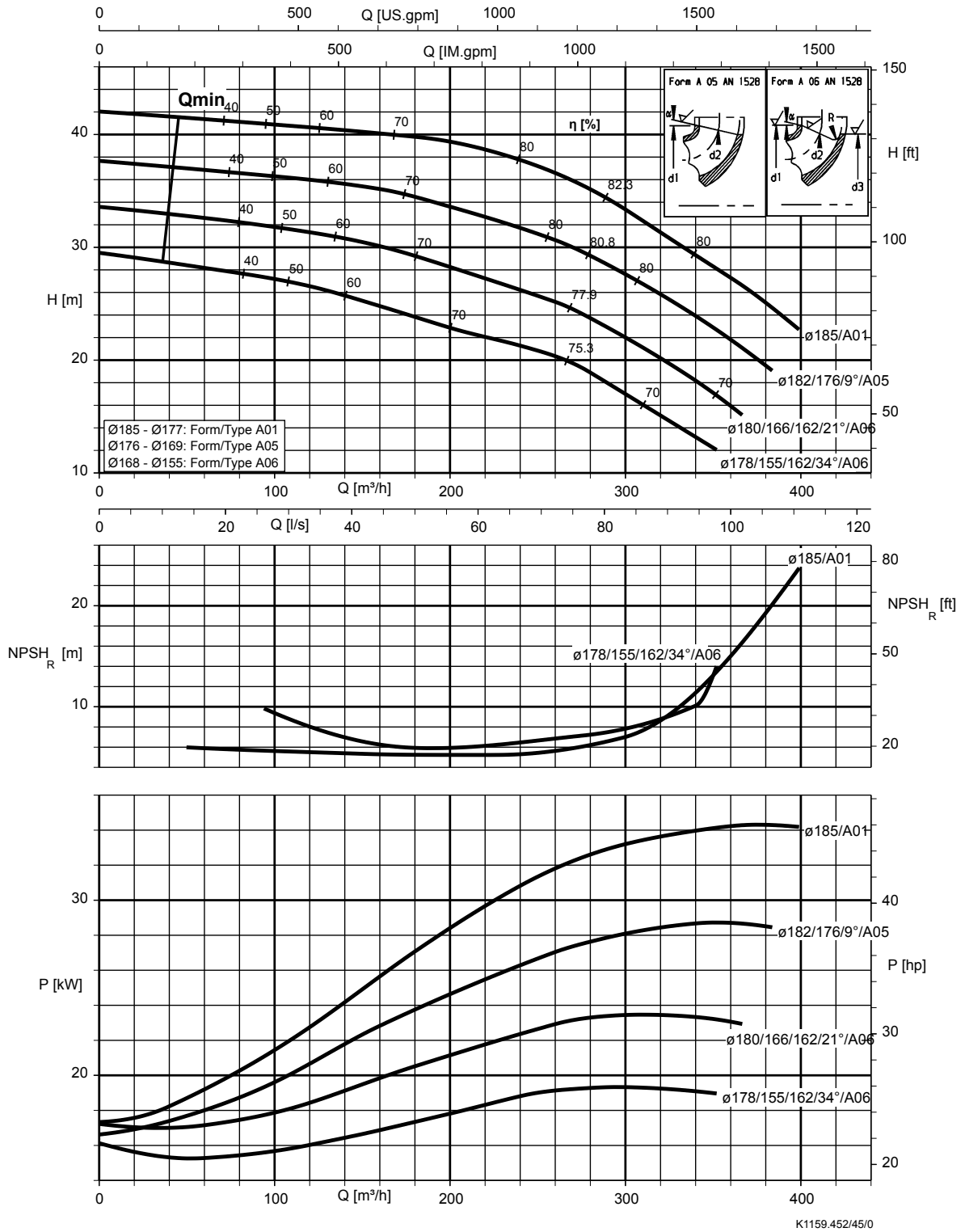

Etaline 125-125-200, n = 2900 rpm

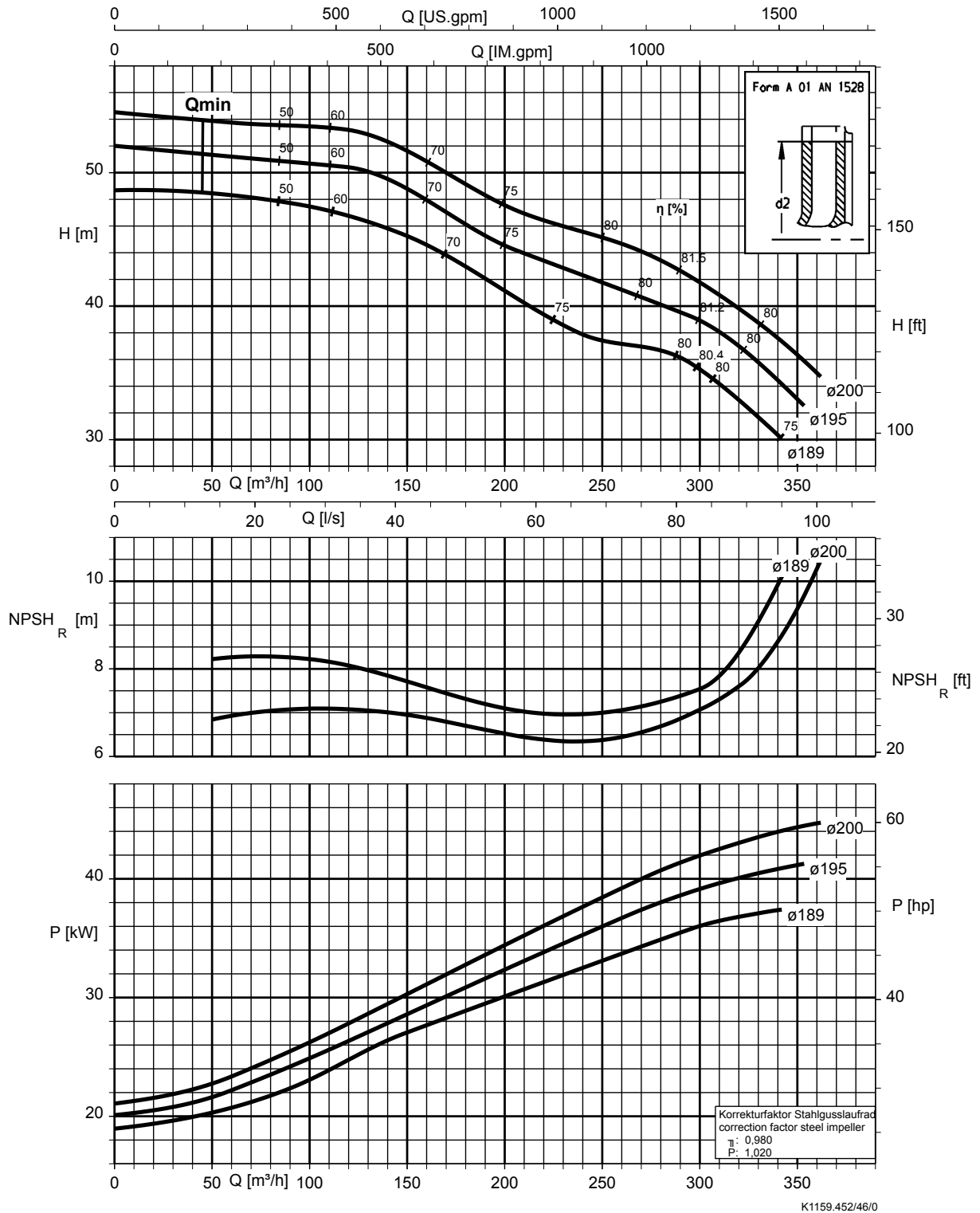

Etaline, n = 1450 rpm

Etaline 032-032-160, n = 1450 rpm

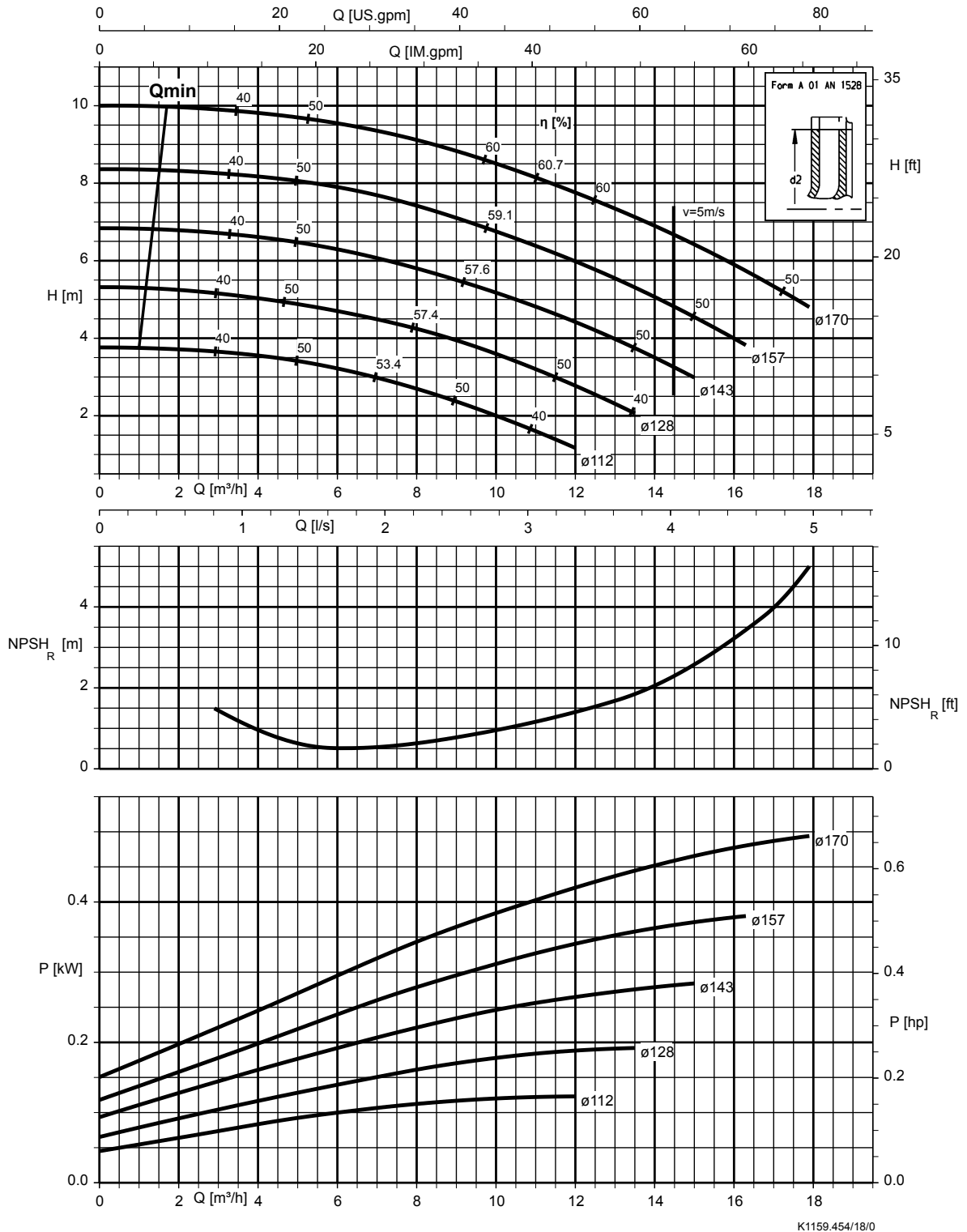

Etaline 032-032-200, n = 1450 rpm

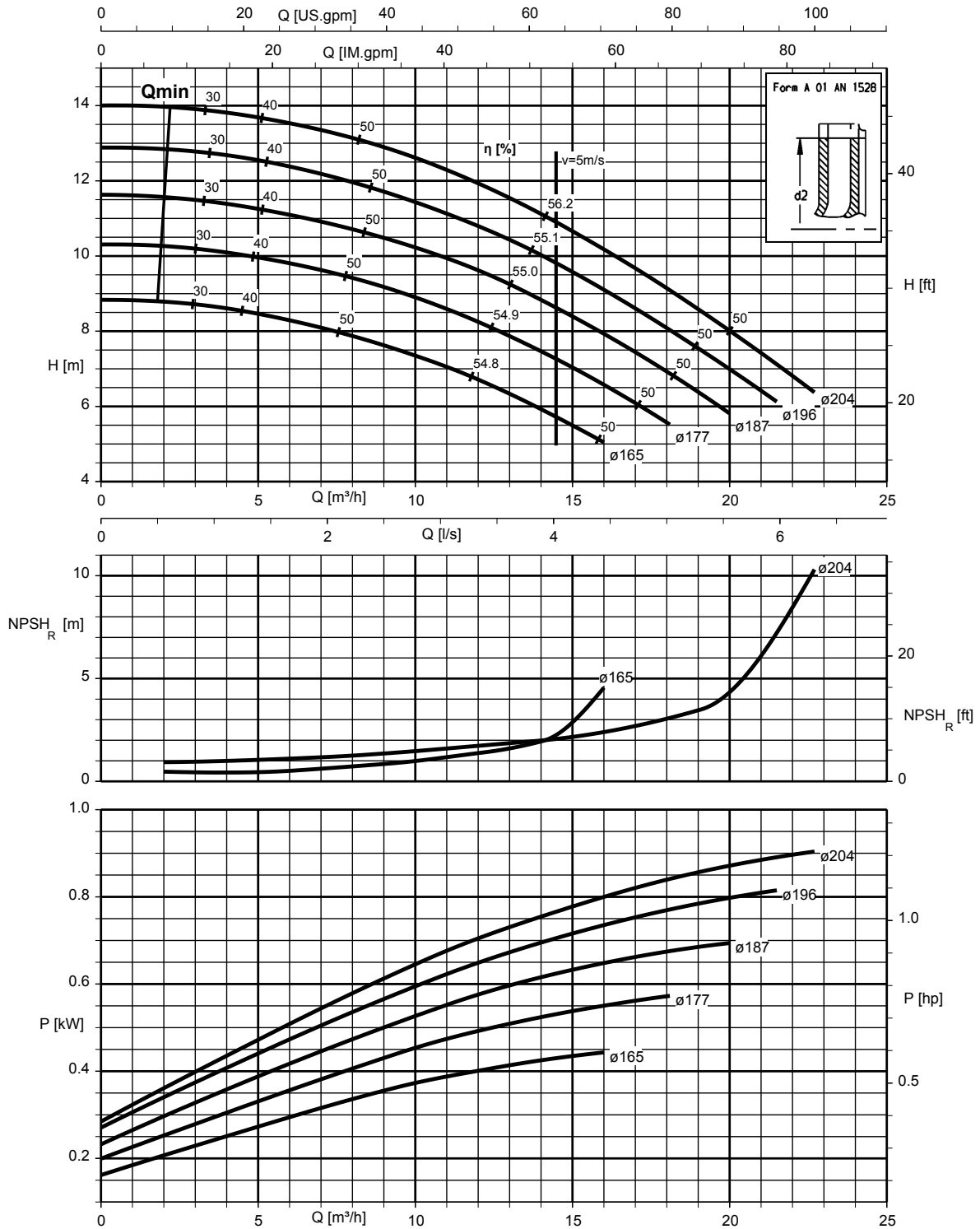

K1159.454/19/0

**Etaline 040-040-160, n = 1450 rpm**

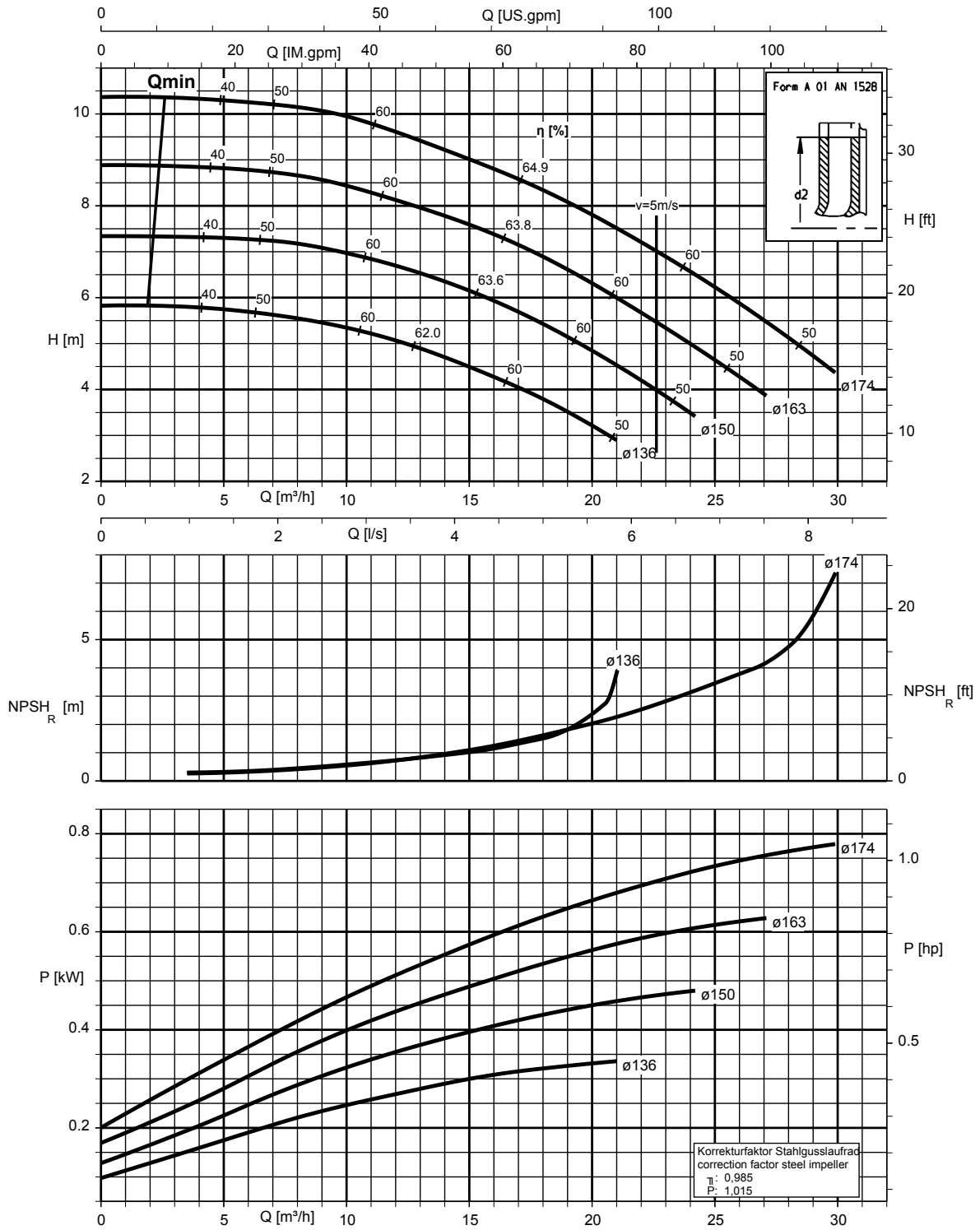

K1159.454/22/0

Etaline 040-040-250, n = 1450 rpm

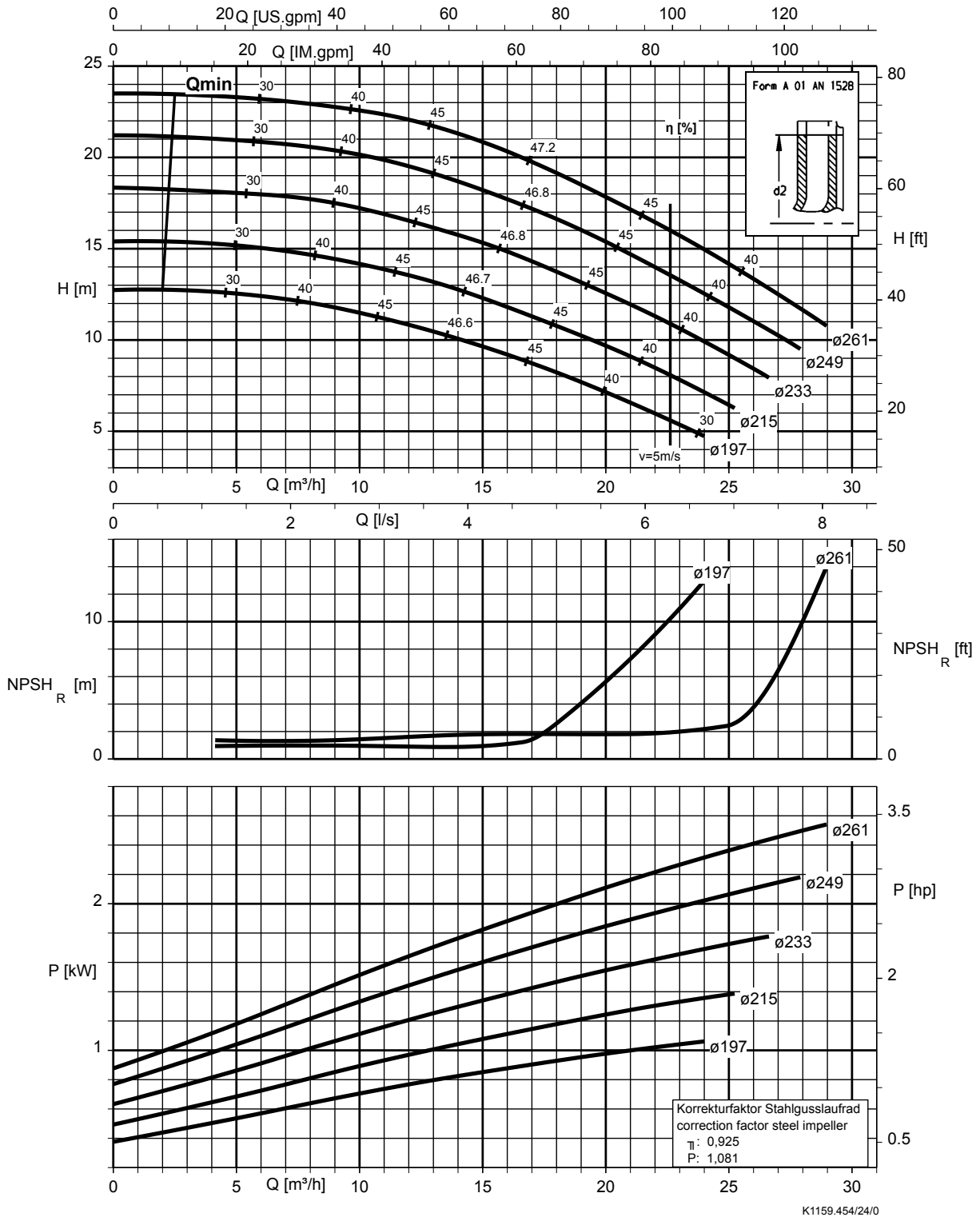

K1159.454/24/0



Etaline 050-050-160, n = 1450 rpm

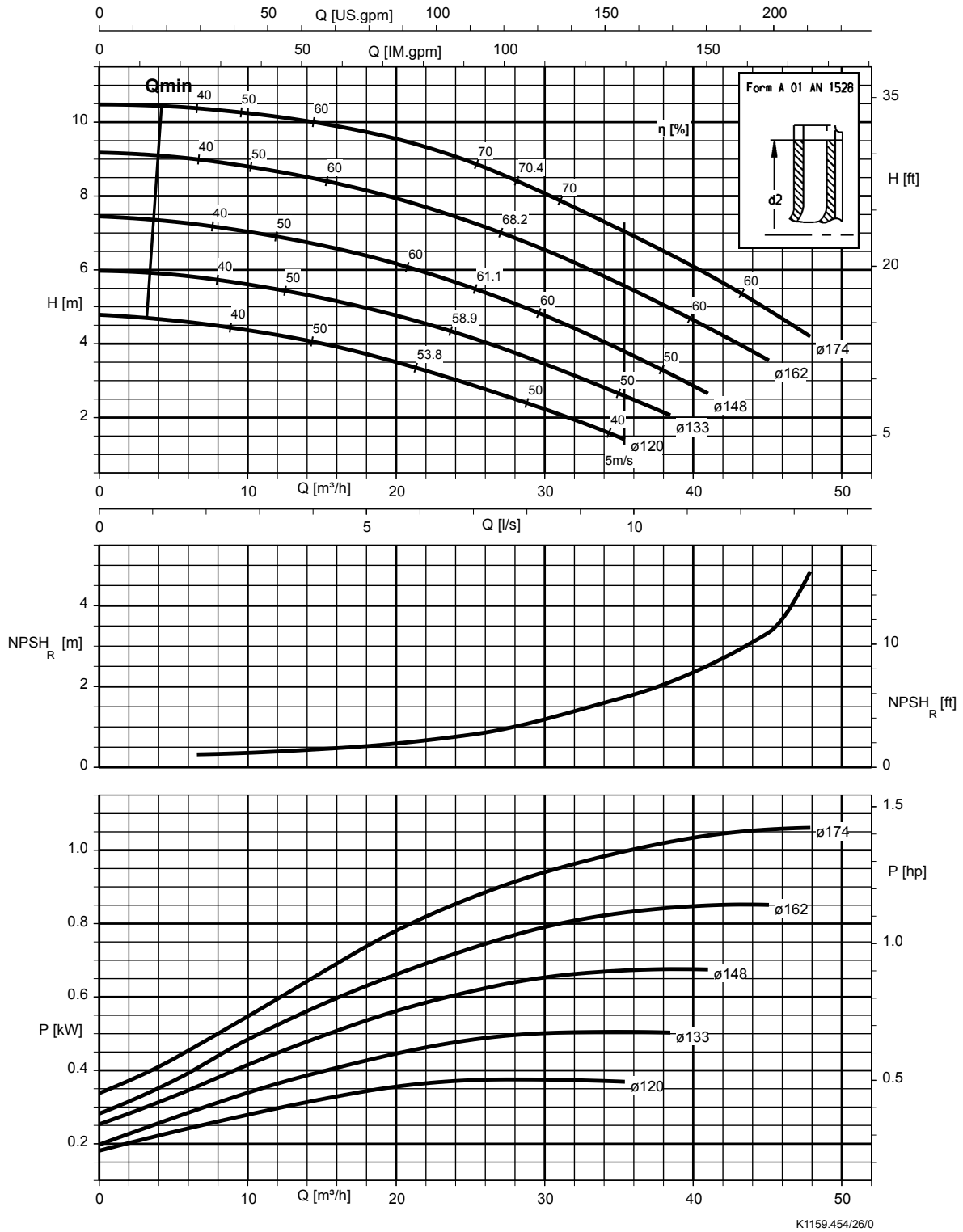

Etaline 050-050-250, n = 1450 rpm

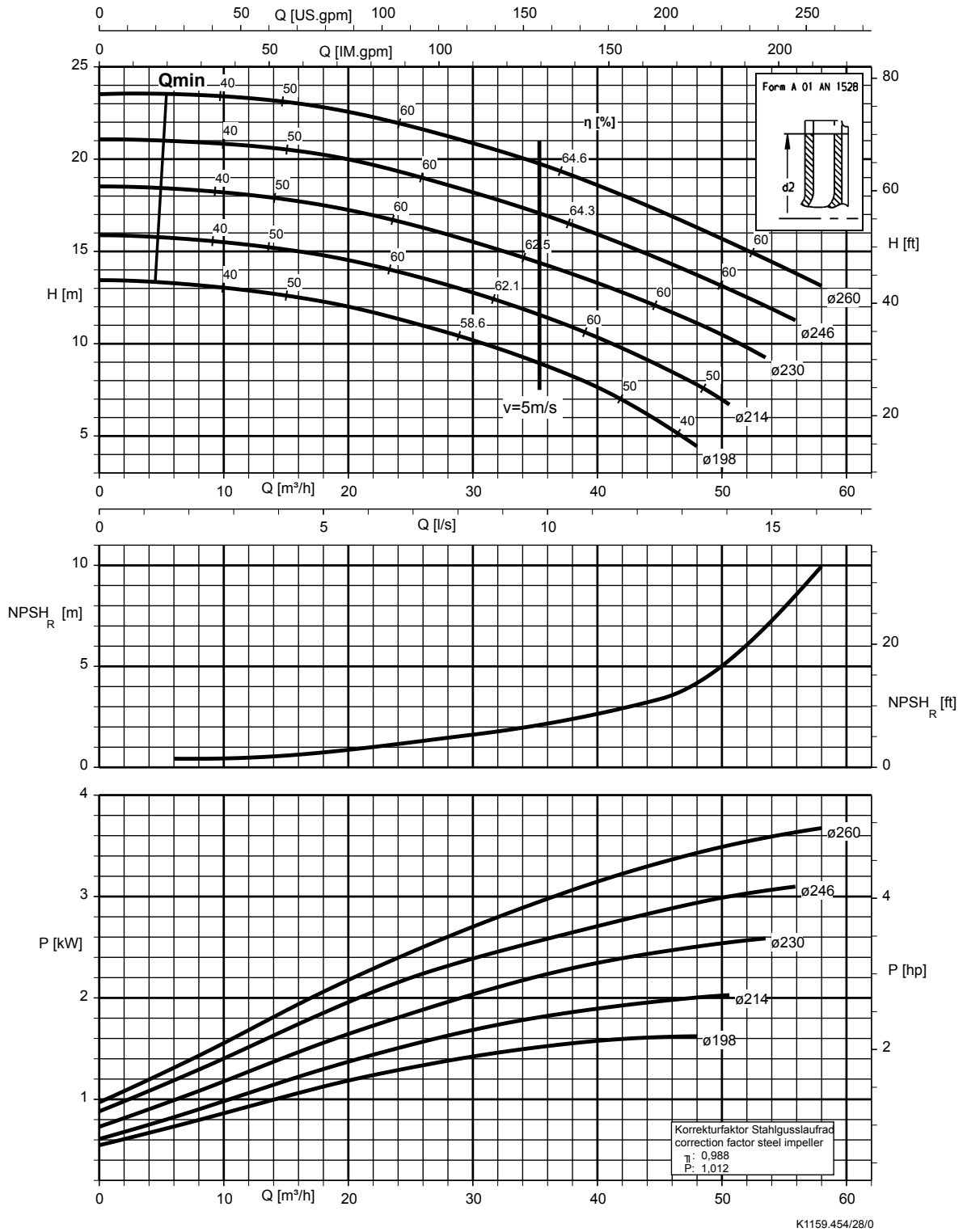

Etaline 065-065-160, n = 1450 rpm

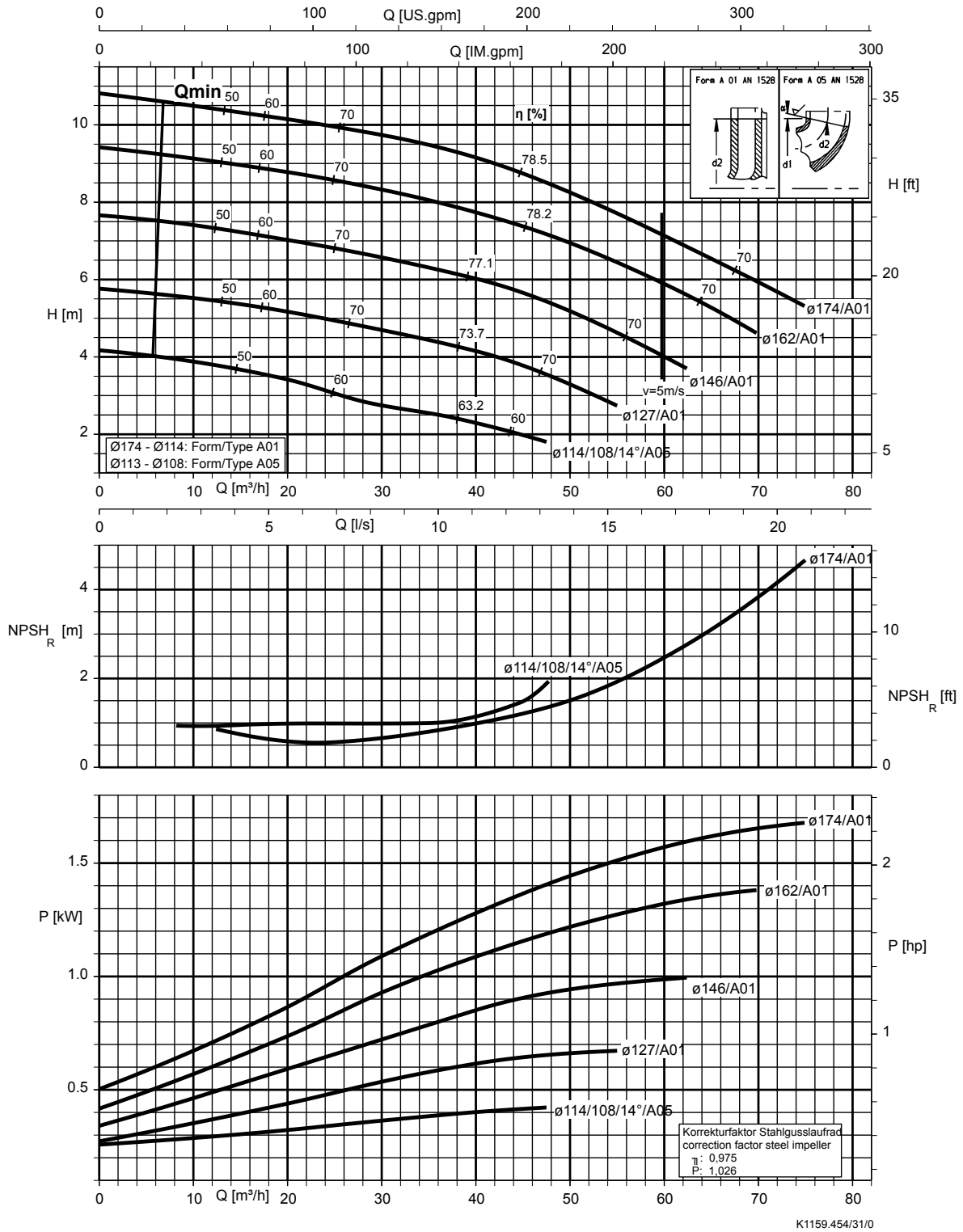

Etaline 065-065-250, n = 1450 rpm

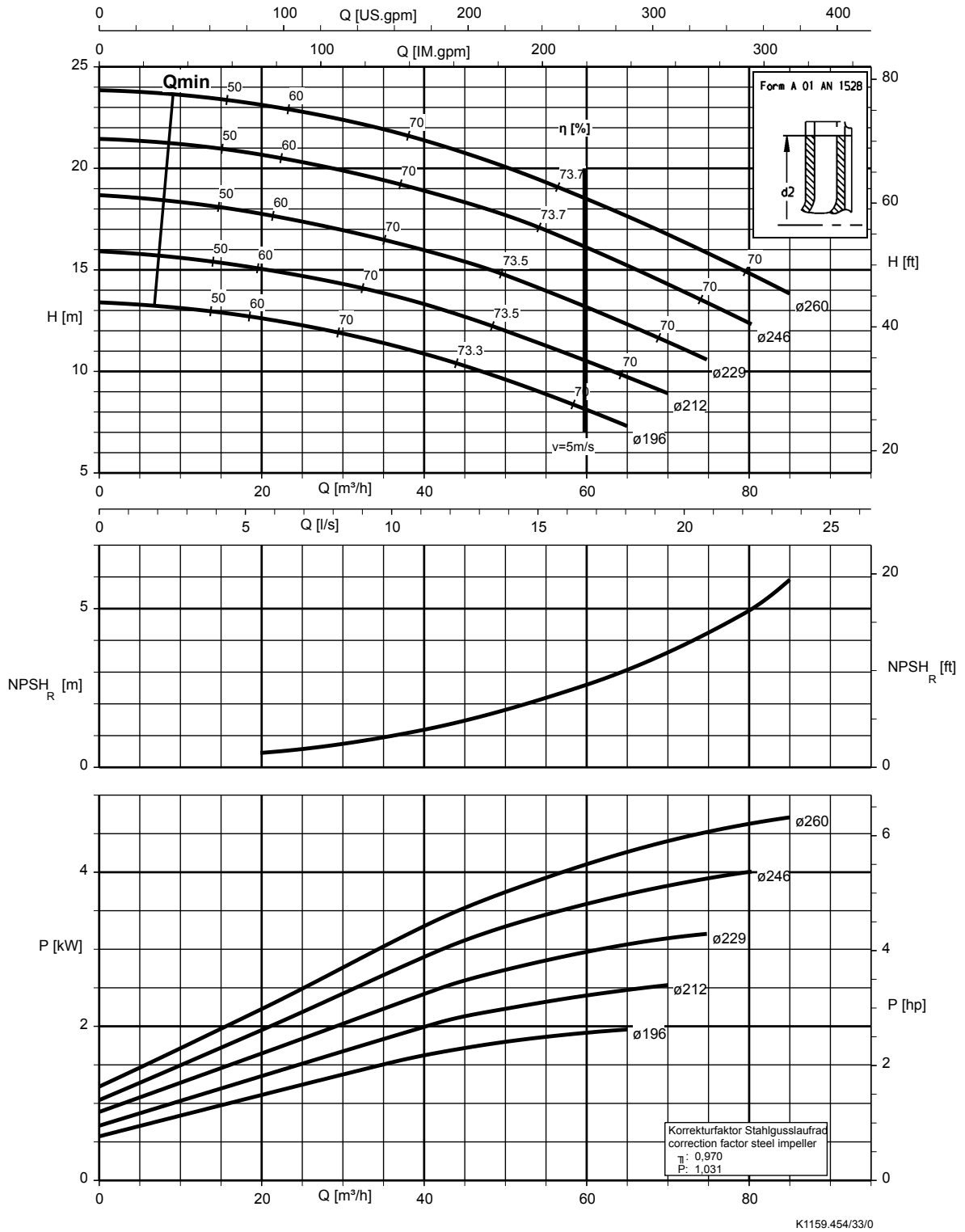

Etaline 080-080-160, n = 1450 rpm

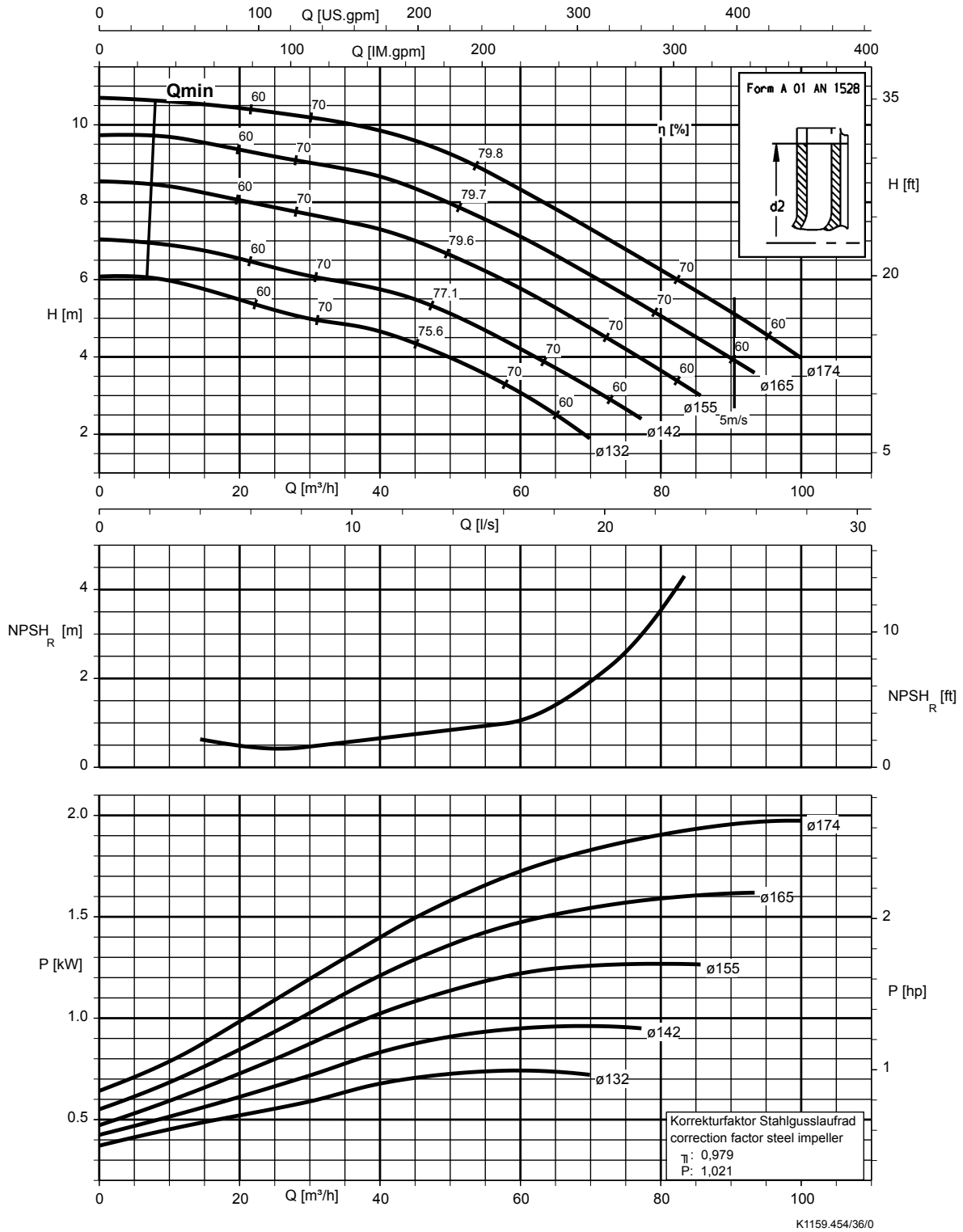

**Etaline 080-080-200, n = 1450 rpm**

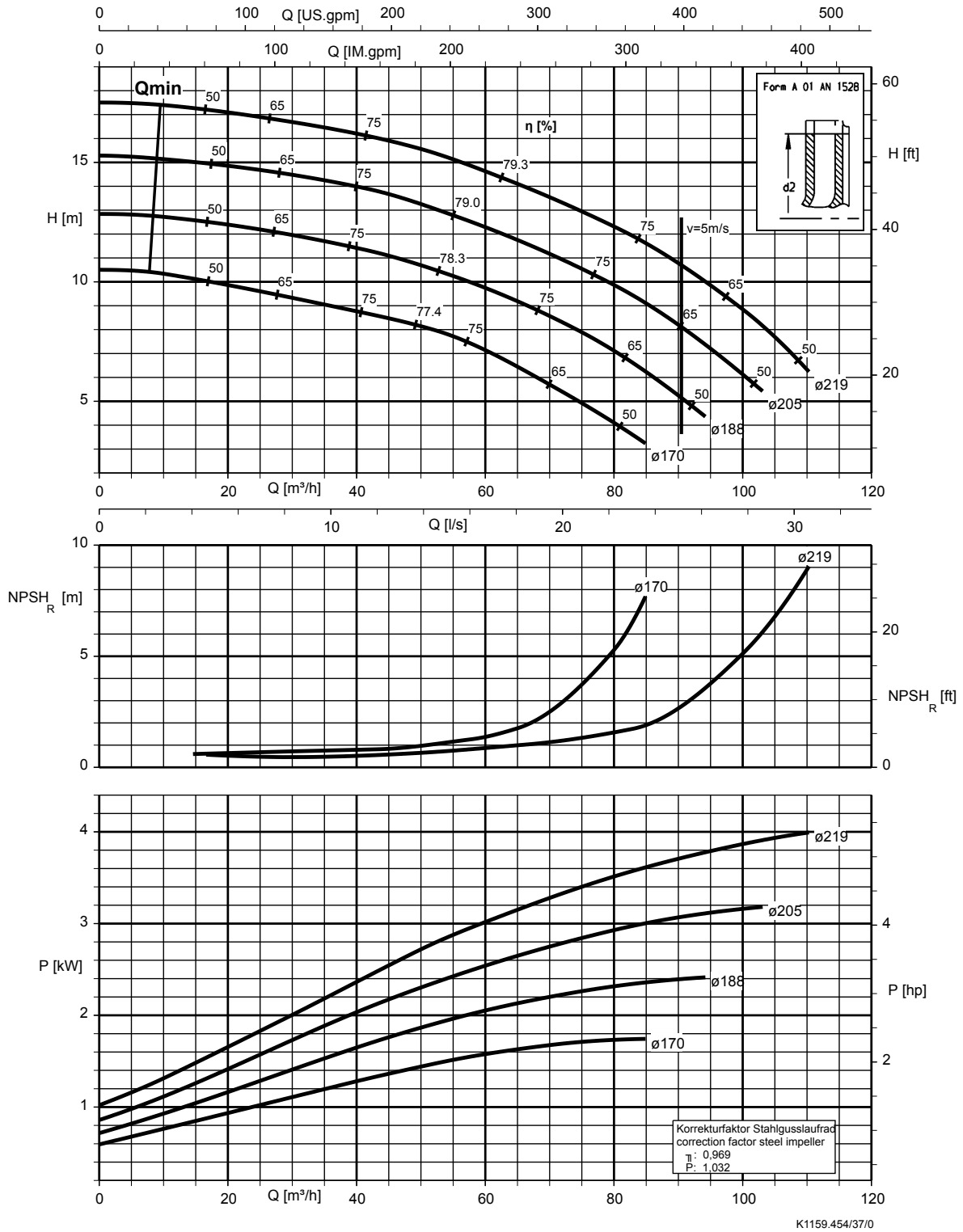

**Etaline 080-080-250, n = 1450 rpm**

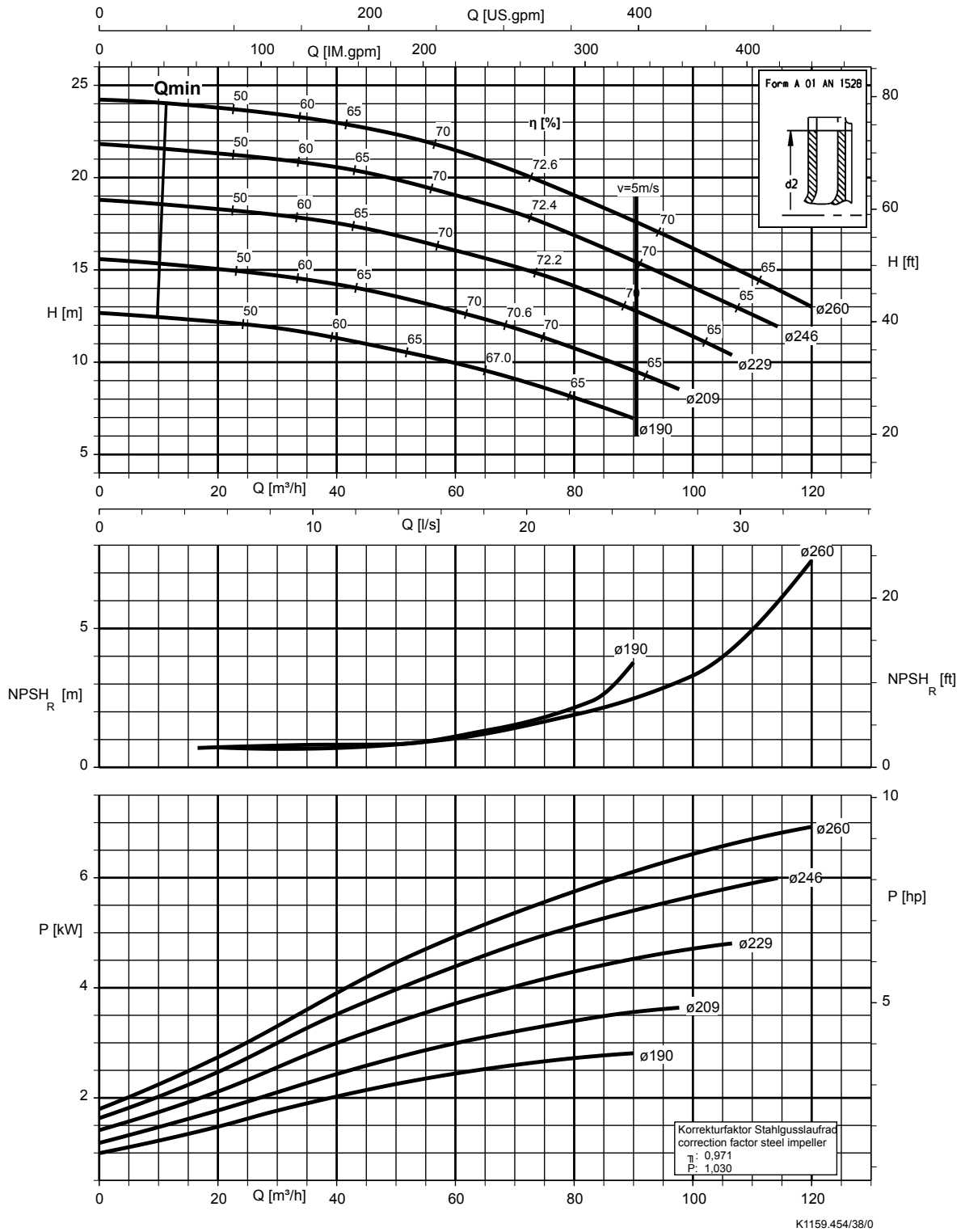

**Etaline 100-100-125, n = 1450 rpm**

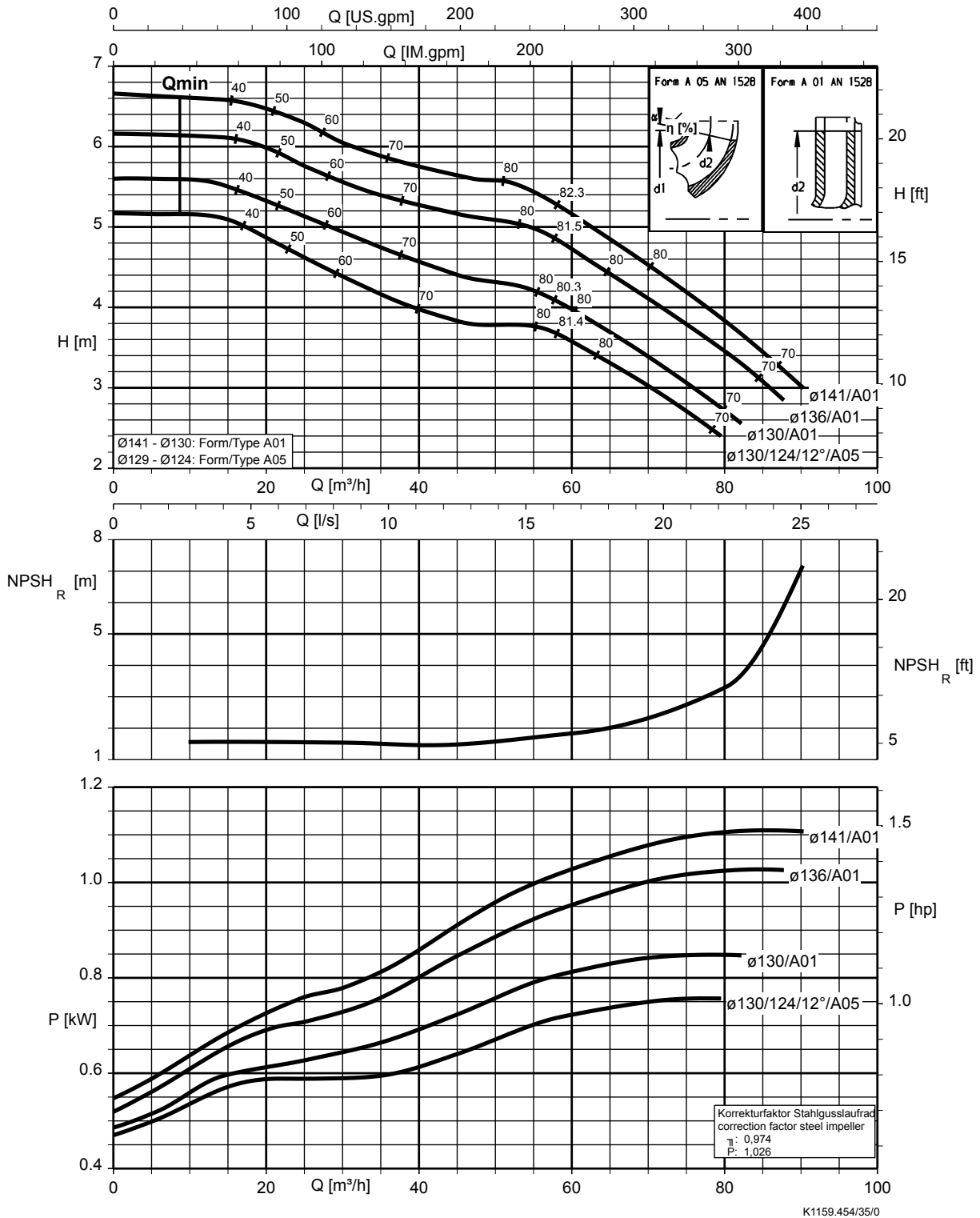



**Etaline 100-100-160, n = 1450 rpm**

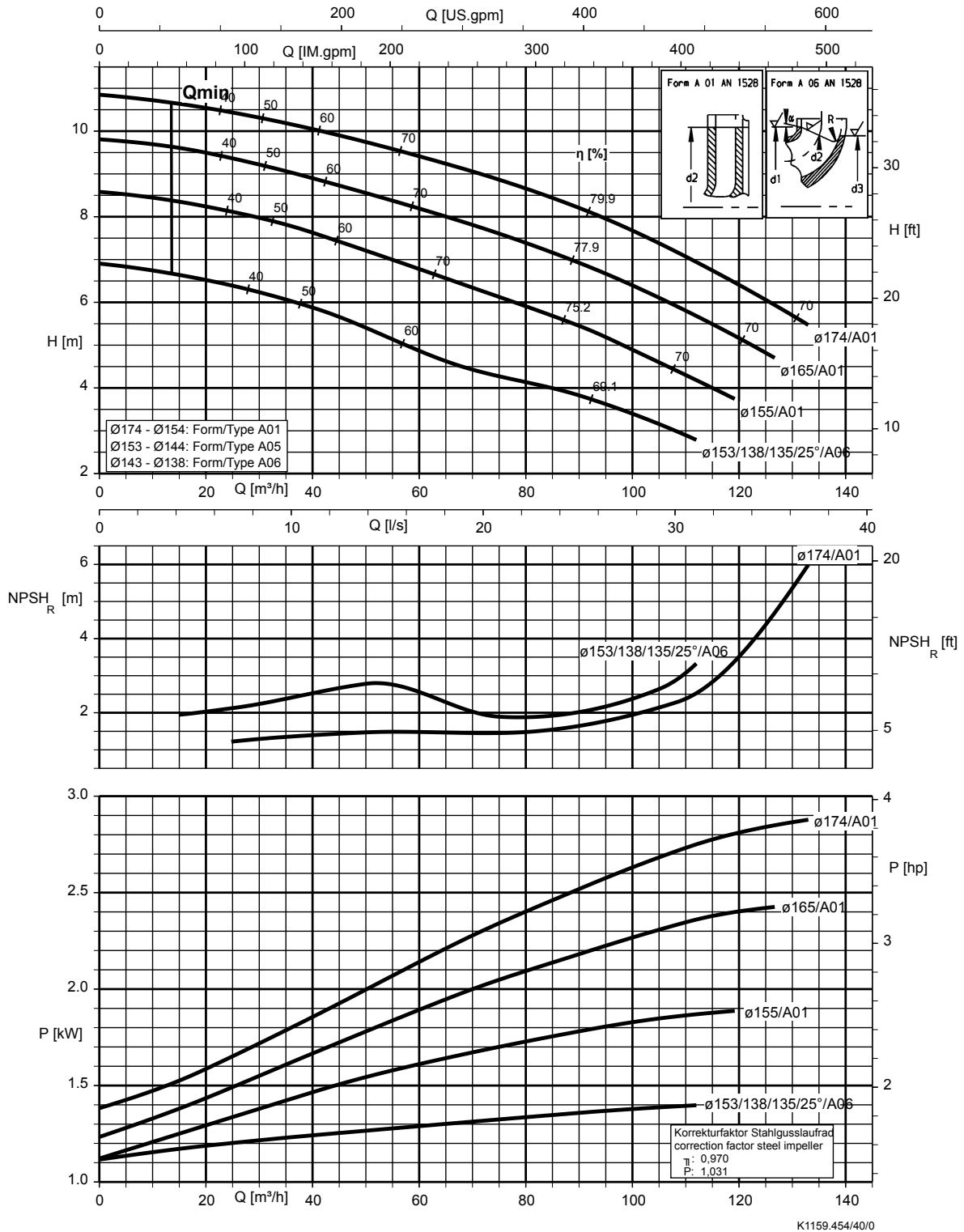

**Etaline 100-100-200, n = 1450 rpm**

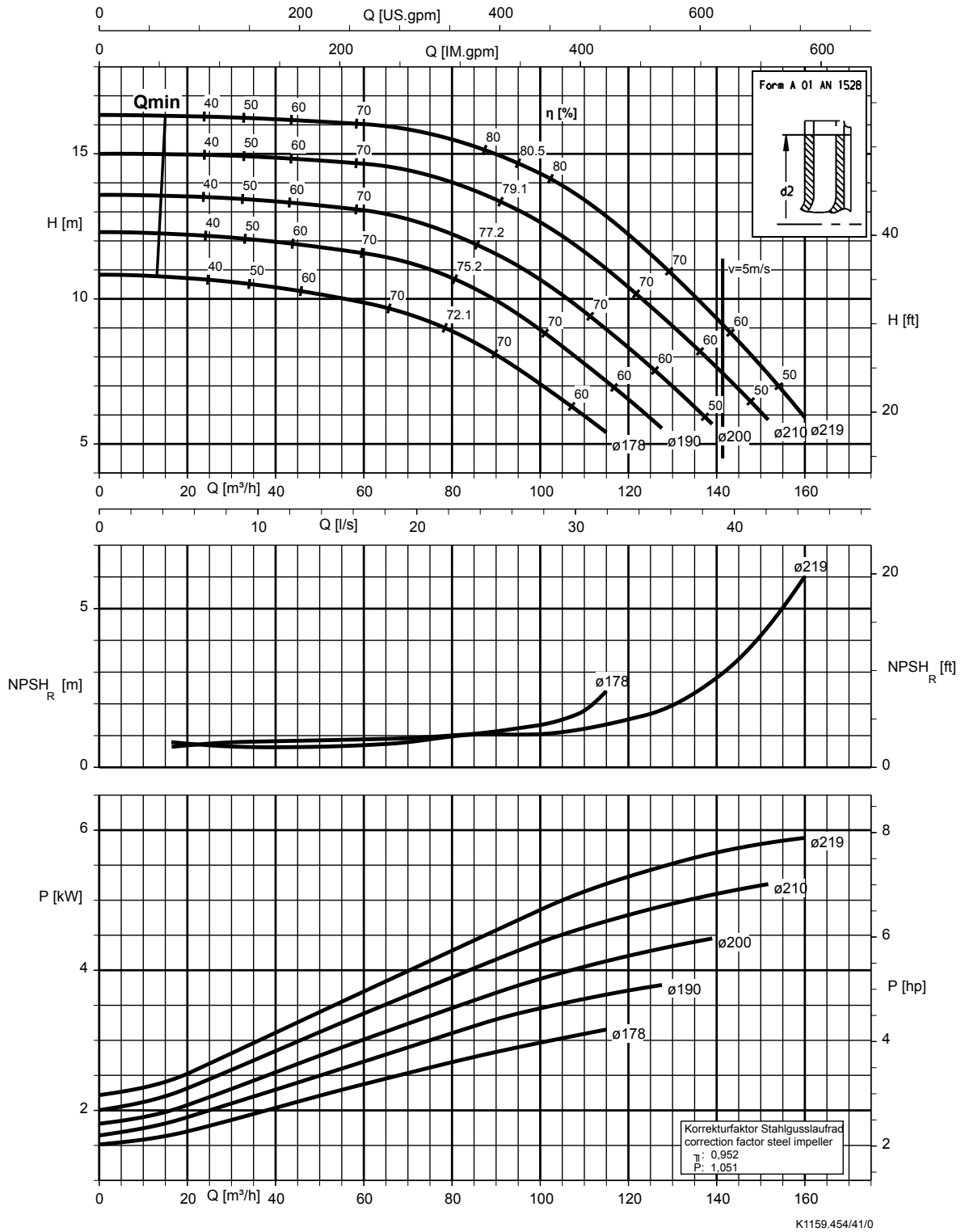

Etaline 100-100-250, n = 1450 rpm

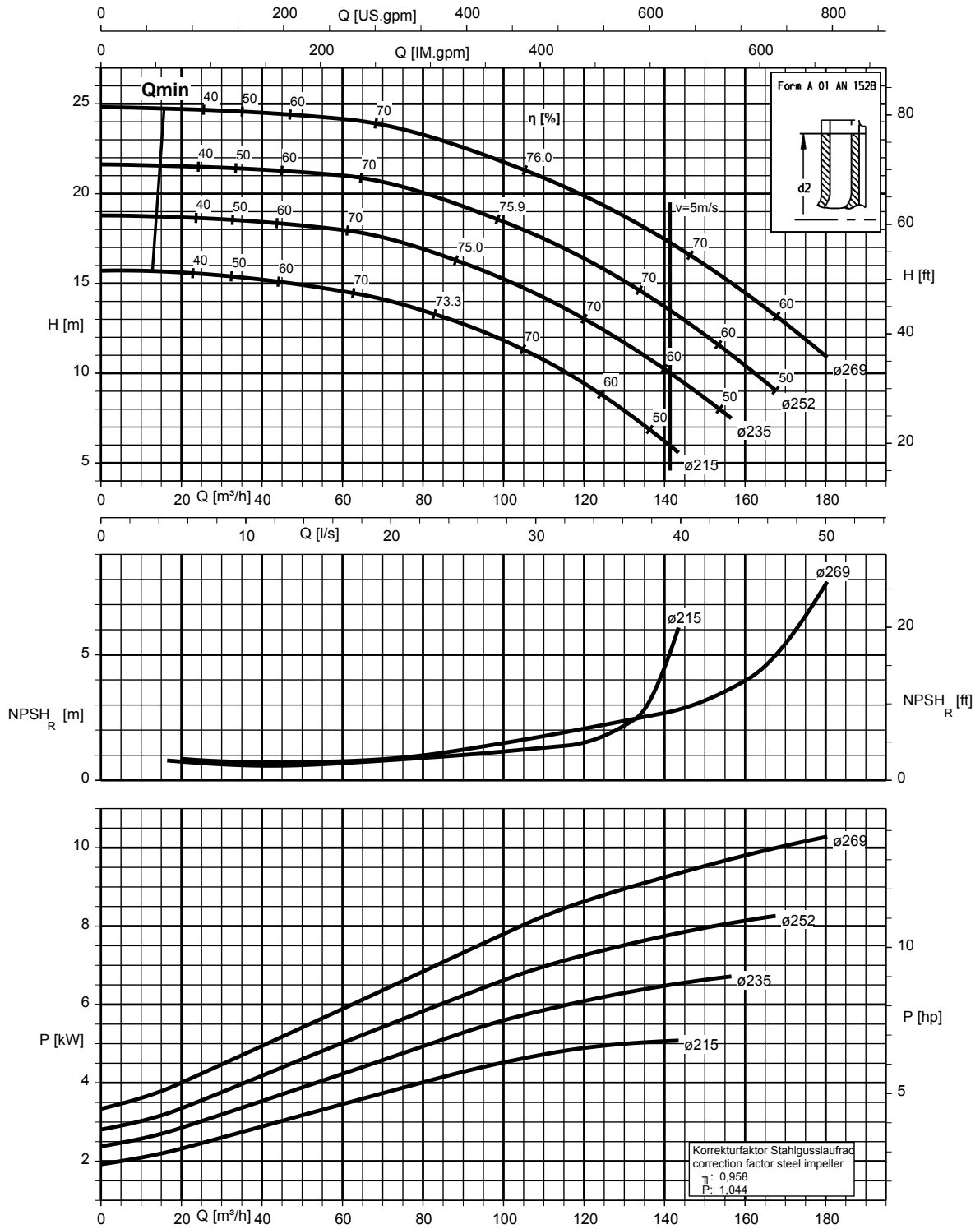

K1159.454/42/0

**Etaline 125-125-160, n = 1450 rpm**

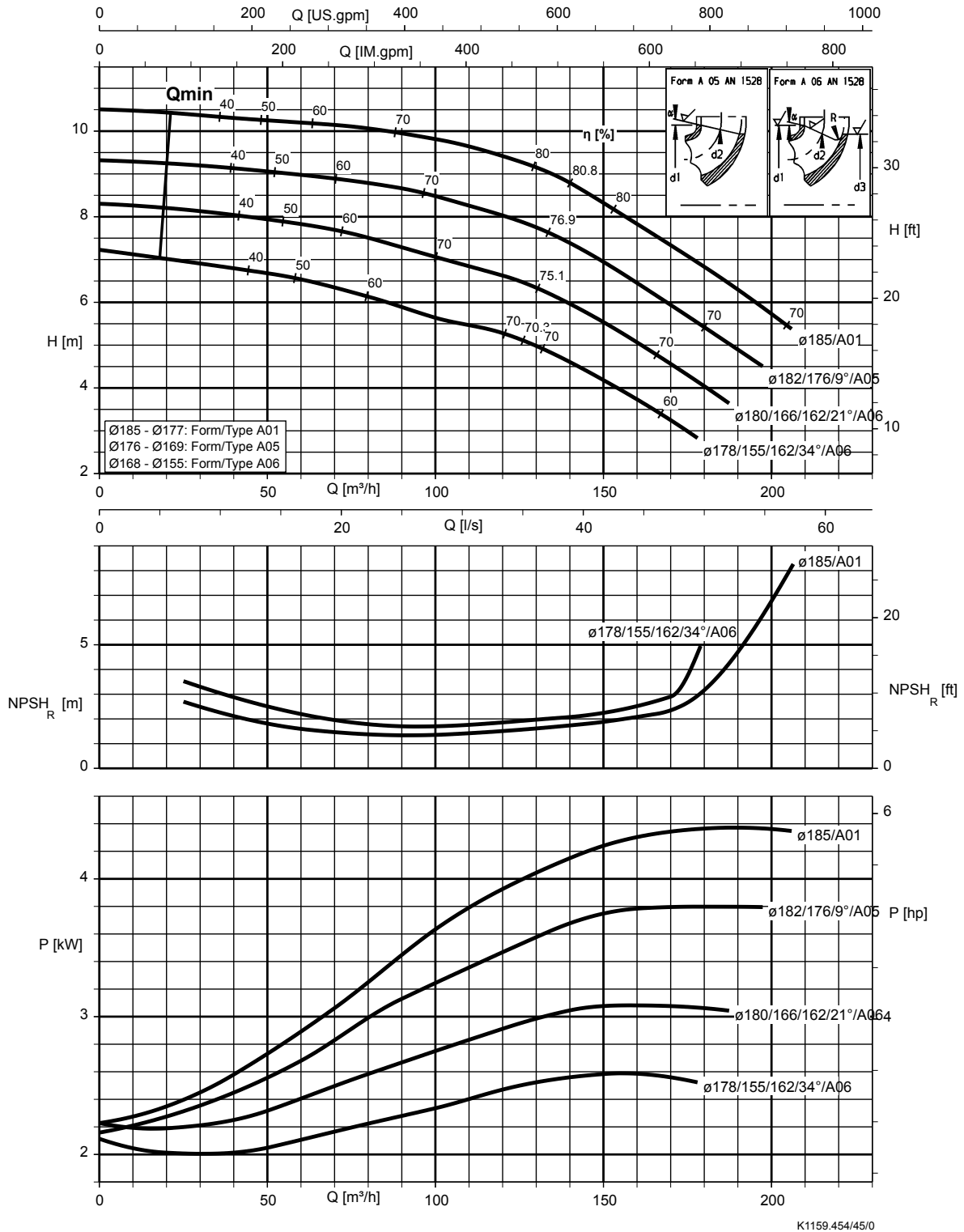

K1159.454/45/0

**Etaline 125-125-200, n = 1450 rpm**

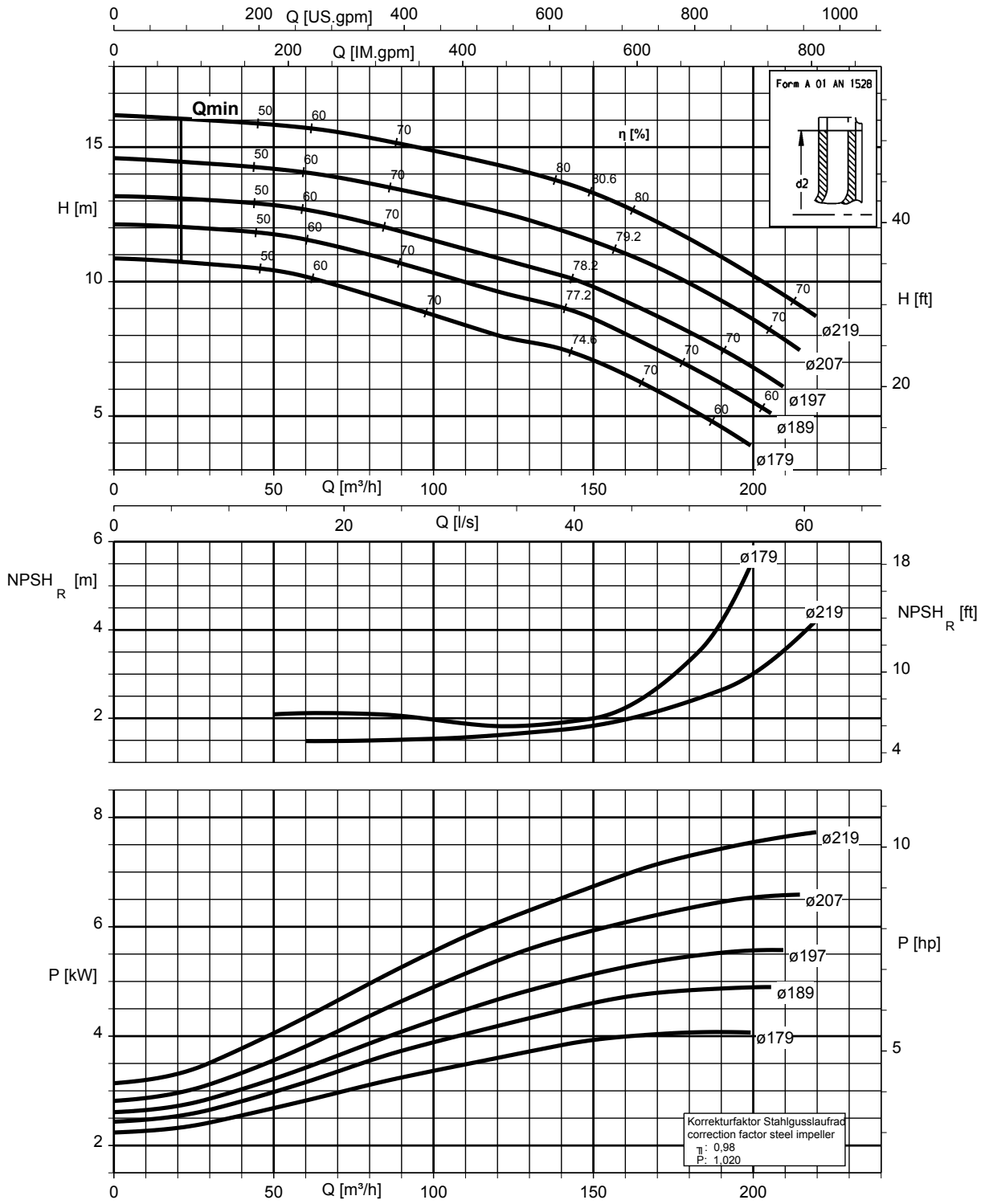

Etaline 125-125-250, n = 1450 rpm

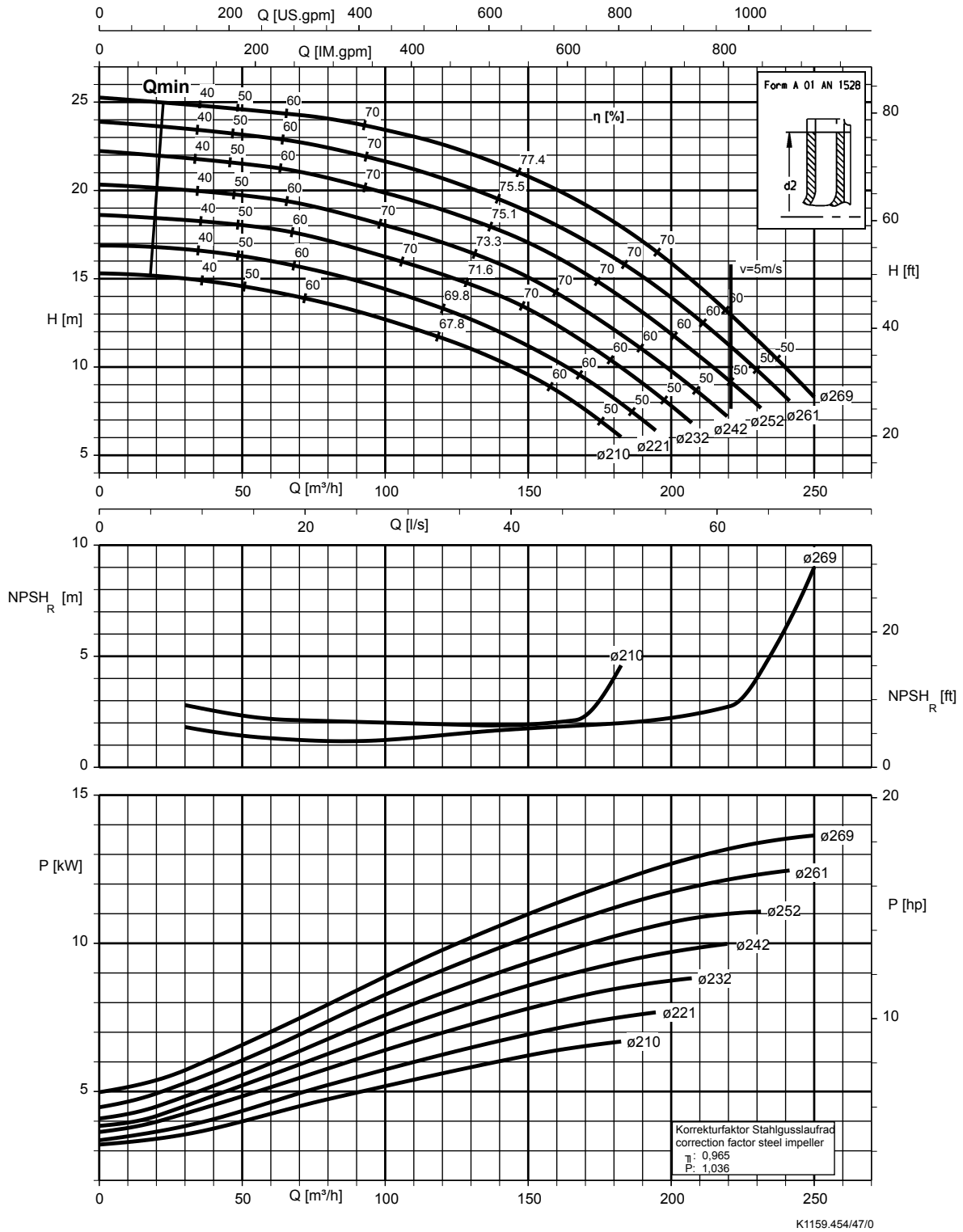

**Etaline 150-150-200, n = 1450 rpm**

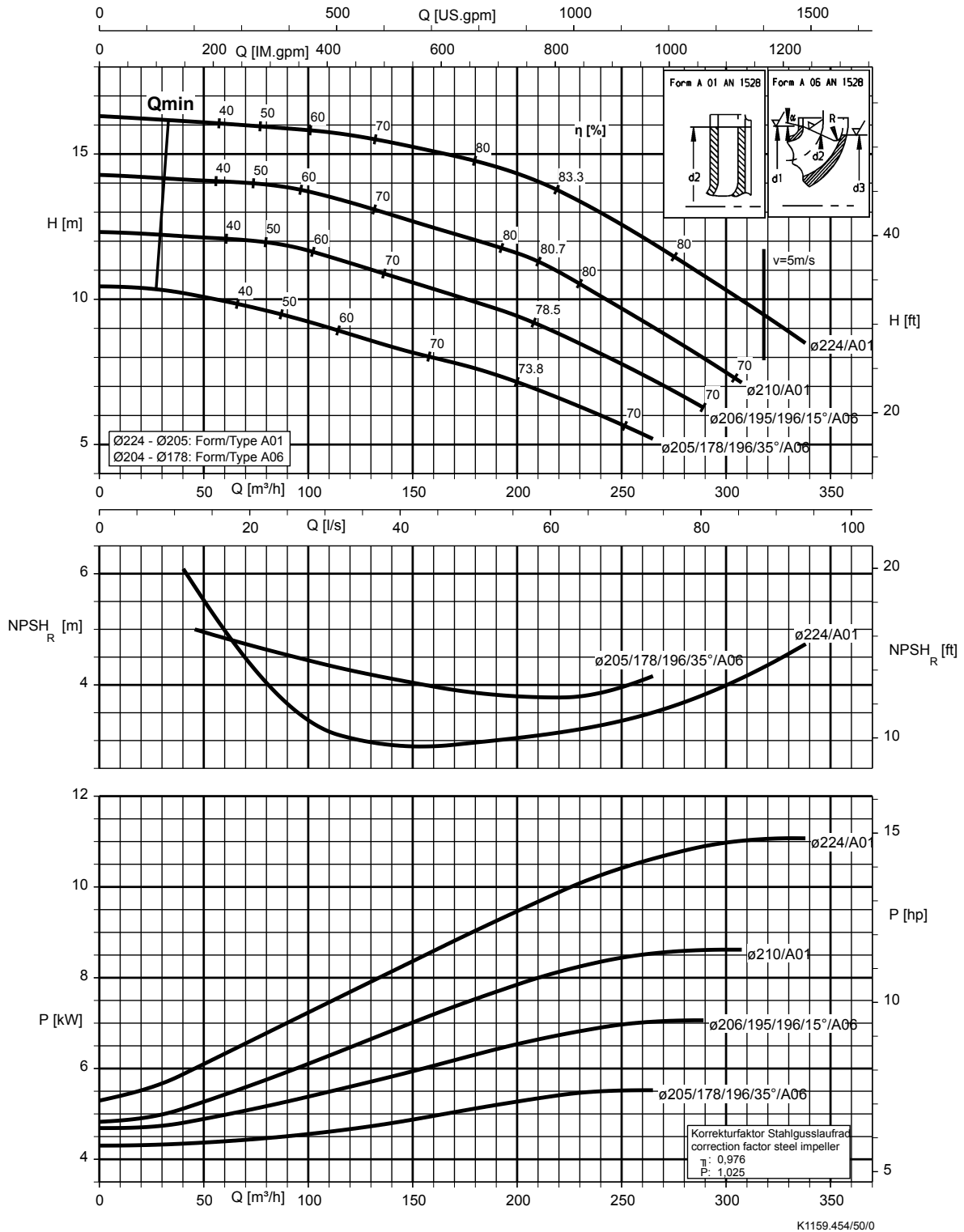

**Etaline 150-150-250, n = 1450 rpm**

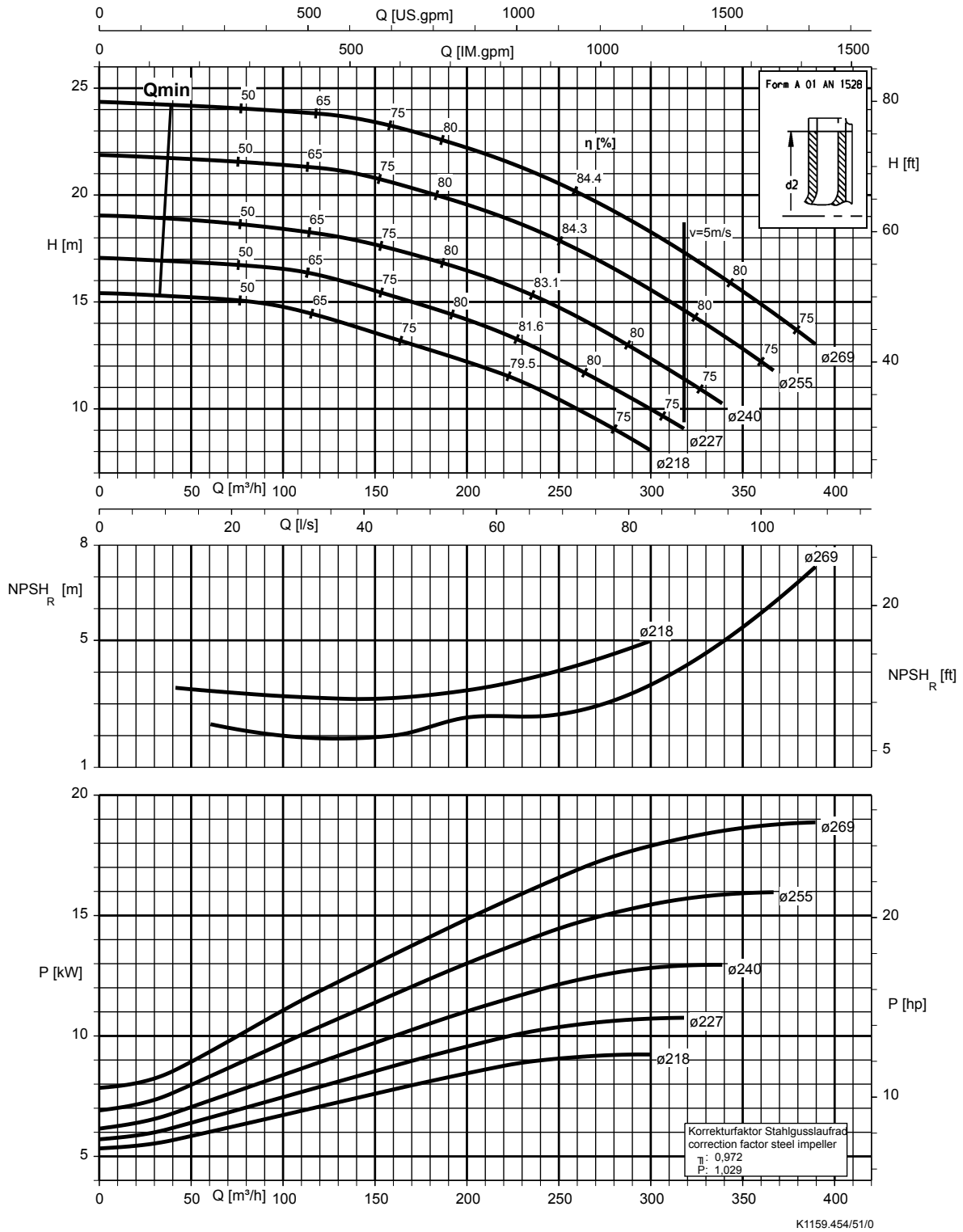



Etaline 200-200-250, n = 1450 rpm

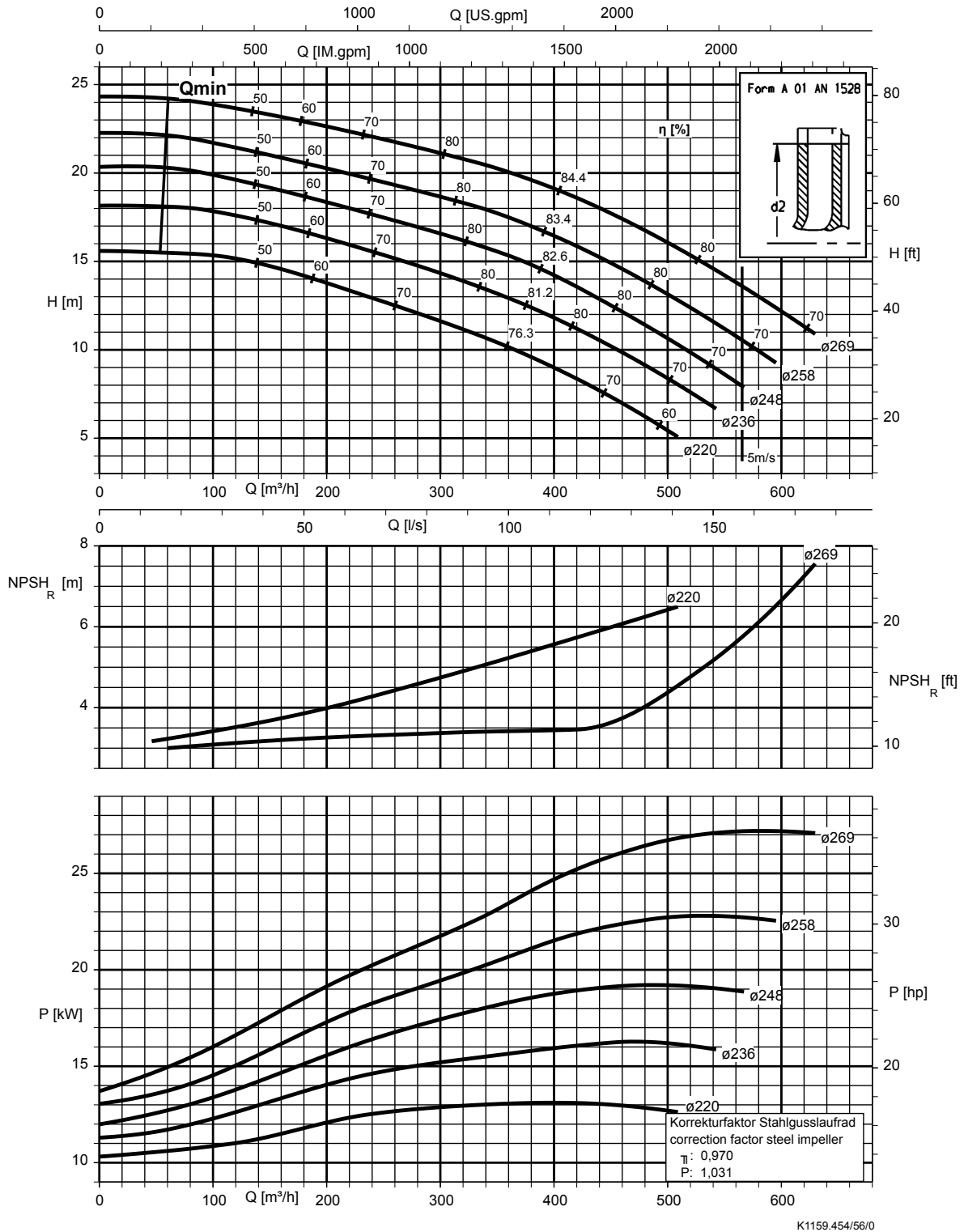

Etaline 200-200-315, n = 1450 rpm

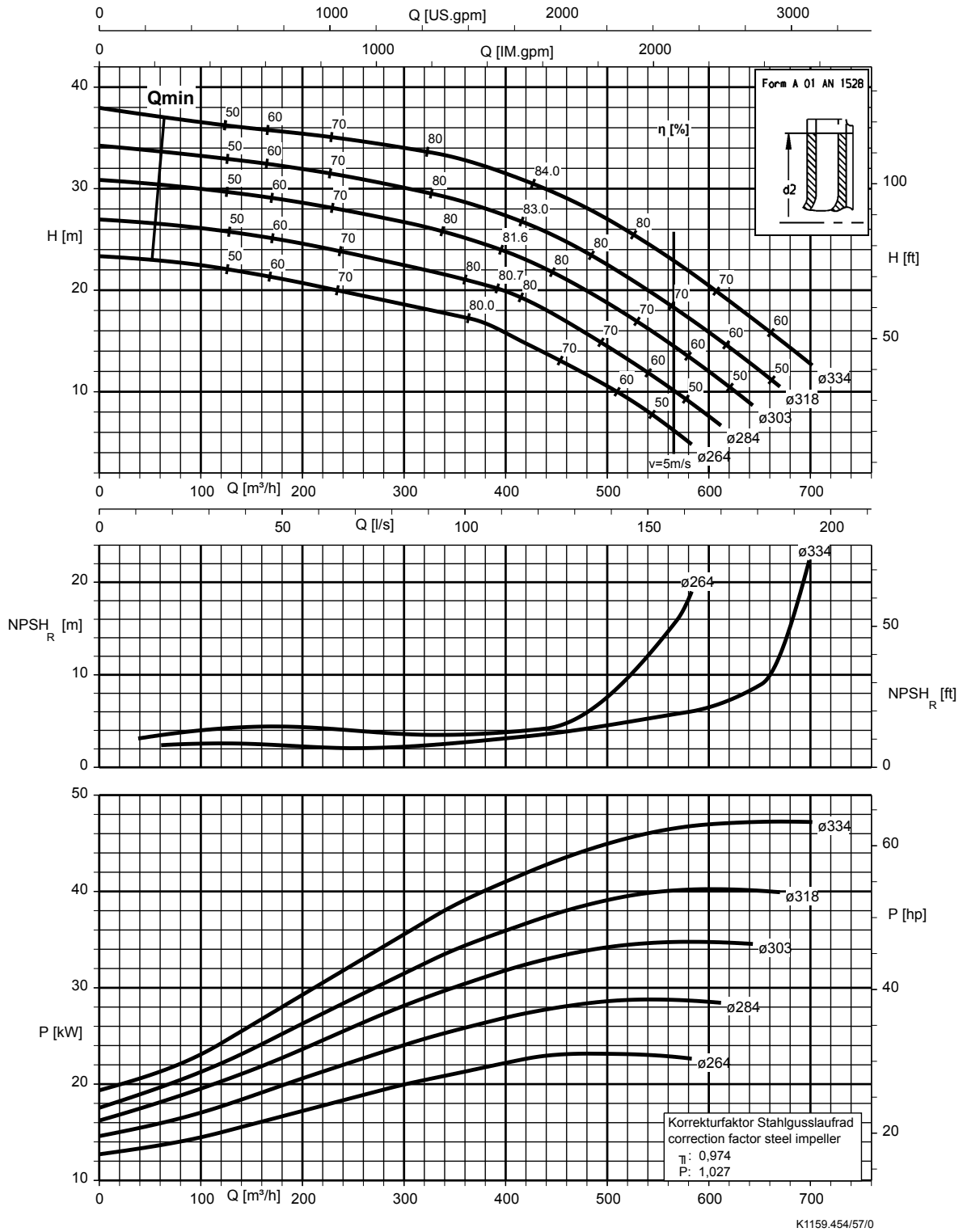

## Dimensions and connections

### Connections

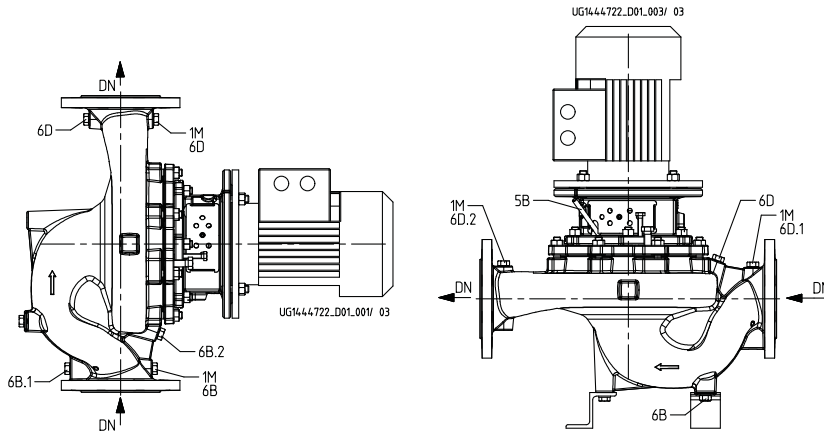

### Connections

#### Connection types

Connection	Description	Configuration	Position
1M	Pressure gauge connection	Drilled and closed, or pressure sensor for PumpMeter (if selected)	Suction and discharge flanges
5B	Vent connection for the mechanical seal chamber	Plugged with vent plug	Casing cover
6B, 6B.1, 6B.2	Fluid drain	Drilled and closed	Volute casing
6D, 6D.1, 6D.2	Fluid priming and venting	Drilled and closed	Volute casing

#### Connection<sup>1)</sup>[mm]

Size	1M, 5B, 6B/1./2, 6D/1./2
032-032-160	Rc 1/4
032-032-200	Rc 1/4
040-040-160	Rc 1/4
040-040-250	Rc 1/4
050-050-160	Rc 1/4
050-050-250	Rc 1/4
065-065-160	Rc 1/4
065-065-250	Rc 1/4
080-080-160	Rc 3/8
080-080-200	Rc 3/8
080-080-250	Rc 3/8
100-100-125	Rc 3/8
100-100-160	Rc 3/8
100-100-200	Rc 3/8
100-100-250	Rc 3/8
125-125-160	Rc 1/2
125-125-200	Rc 1/2
125-125-250	Rc 1/2
150-150-200	Rc 1/2
150-150-250	Rc 1/2
200-200-250	Rc 1/2
200-200-315	Rc 1/2

1) Rc=ISO 7/1

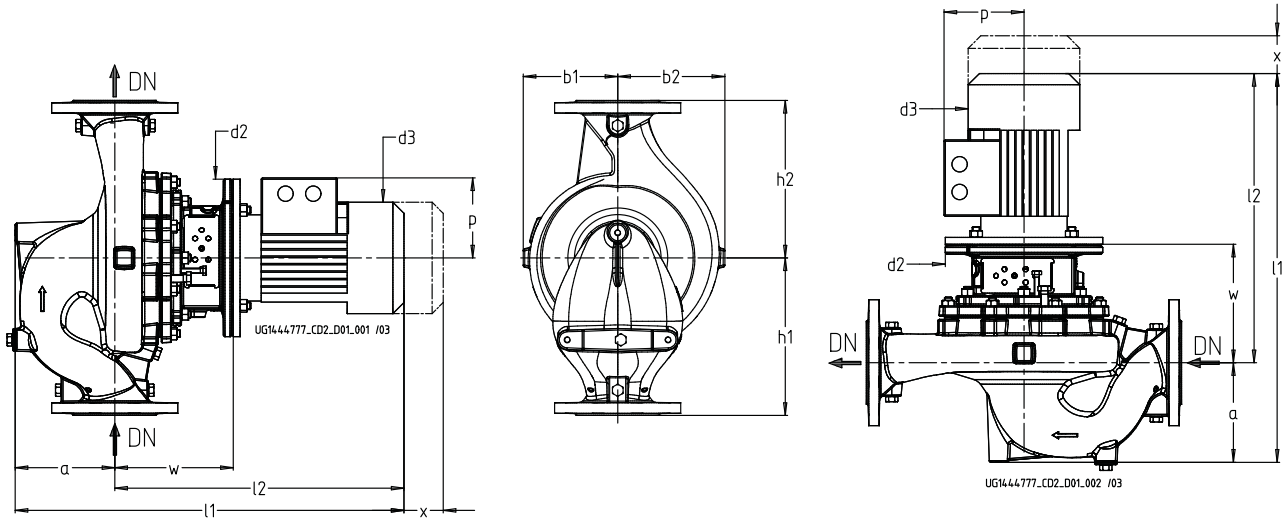
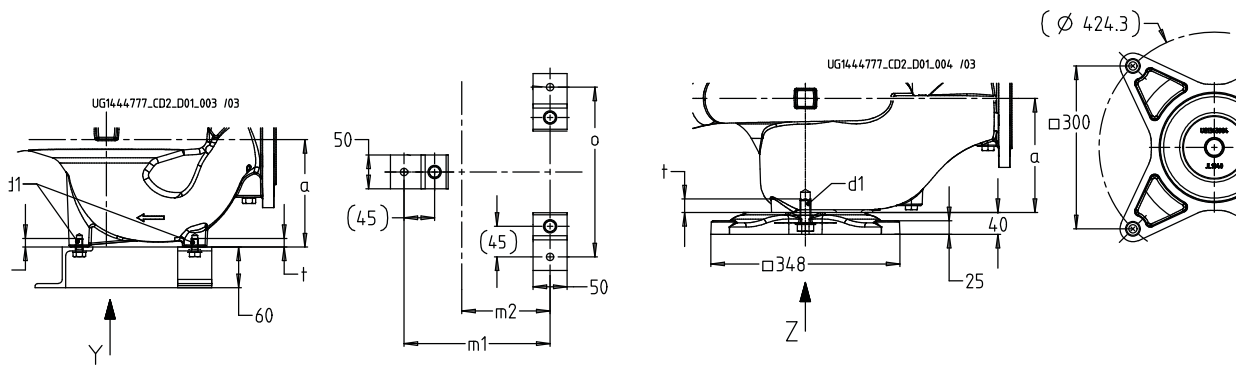
**Dimensions**
**Etaline, n = 2900 rpm**

**Pump set dimensions**

**Foundation fastening dimensions**
**Dimensions**

Size	Motor	DN <sub>1</sub> 12)	a	~b <sub>1</sub> 13)	~b <sub>2</sub> 13)	d <sub>1</sub>	d <sub>2</sub>	d <sub>3</sub>	p	h <sub>1</sub>	h <sub>2</sub>	~l <sub>1</sub> 13)	~l <sub>2</sub> 13)	t	~x 13)	w	m <sub>1</sub>	m <sub>2</sub>	o
	[kW]																		
032-032-160	1,1	32	87	119	131	M10	200	162	120	180	160	512	425	12,5	100	156	175	100	190
032-032-160	1,5	32	87	119	131	M10	200	190	128	180	160	525	438	12,5	100	156	175	100	190
032-032-160	2,2	32	87	119	131	M10	200	190	128	180	160	551	464	12,5	100	156	175	100	190
032-032-160	3,0	32	87	119	131	M10	250	213	135	180	160	604	517	12,5	100	170	175	100	190
032-032-160	4,0	32	87	119	131	M10	250	234	148	180	160	628	541	12,5	100	170	175	100	190
032-032-160	5,5	32	87	119	131	M10	300	266	167	180	160	693	606	12,5	100	193	175	100	190
032-032-160	7,5	32	87	119	131	M10	300	266	167	180	160	693	606	12,5	100	193	175	100	190
032-032-200	3,0	32	100	134	146	M10	250	213	135	250	190	617	517	12,5	100	170	175	100	190
032-032-200	4,0	32	100	134	146	M10	250	234	148	250	190	641	541	12,5	100	170	175	100	190
032-032-200	5,5	32	100	134	146	M10	300	266	167	250	190	706	606	12,5	100	193	175	100	190
032-032-200	7,5	32	100	134	146	M10	300	266	167	250	190	706	606	12,5	100	193	175	100	190
032-032-200	11,0	32	100	134	146	M10	350	325	197	250	190	872	772	12,5	100	226	175	100	190
032-032-200	15,0	32	100	134	146	M10	350	325	197	250	190	872	772	12,5	100	226	175	100	190

12) DN = EN 1092-2, PN 16

13) For the exact motor-related dimensions refer to the general arrangement drawing.



Size	Motor	DN <sub>1</sub> 12)	a	$\sim b_1$ 13)	$\sim b_2$ 13)	d <sub>1</sub>	d <sub>2</sub>	d <sub>3</sub>	p	h <sub>1</sub>	h <sub>2</sub>	$\sim l_1$ 13)	$\sim l_2$ 13)	t	$\sim x$ 13)	w	m <sub>1</sub>	m <sub>2</sub>	o
	[kW]	[mm]																	
100-100-125	15,0	100	129	112	160	M10	350	325	197	230	220	910	781	12,5	100	235	195	100	230
100-100-160	11,0	100	156	128	163	M20	350	325	197	245	205	948	792	25	140	246	-	-	-
100-100-160	15,0	100	156	128	163	M20	350	325	197	245	205	948	792	25	140	246	-	-	-
100-100-160	18,5	100	156	128	163	M20	350	325	197	245	205	954	798	25	140	246	-	-	-
100-100-160	22,0	100	156	128	163	M20	350	370	262	245	205	1012	856	25	140	246	-	-	-
100-100-160	30,0	100	156	128	163	M20	400	422	305	245	205	1071	915	25	140	246	-	-	-
100-100-160	37,0	100	156	128	163	M20	400	422	305	245	205	1071	915	25	140	246	-	-	-
125-125-160	18,5	125	203	182	226	M20	350	325	197	420	280	1001	798	25	140	246	-	-	-
125-125-160	22,0	125	203	182	226	M20	350	370	262	420	280	1059	856	25	140	246	-	-	-
125-125-160	30,0	125	203	182	226	M20	400	422	305	420	280	1118	915	25	140	246	-	-	-
125-125-160	37,0	125	203	182	226	M20	400	422	305	420	280	1118	915	25	140	246	-	-	-
125-125-160	45,0	125	203	182	226	M20	450	468	325	420	280	1235	1032	25	140	277	-	-	-
125-125-200	22,0	125	206	175	214	M20	350	370	262	380	320	1062	856	25	140	246	-	-	-
125-125-200	30,0	125	206	175	214	M20	400	422	305	380	320	1121	915	25	140	246	-	-	-
125-125-200	37,0	125	206	175	214	M20	400	422	305	380	320	1065	859	25	140	190	-	-	-
125-125-200	45,0	125	206	175	214	M20	450	468	325	380	320	1238	1032	25	140	277	-	-	-

12) DN = EN 1092-2, PN 16

13) For the exact motor-related dimensions refer to the general arrangement drawing.

**Etaline, n = 1450 rpm**

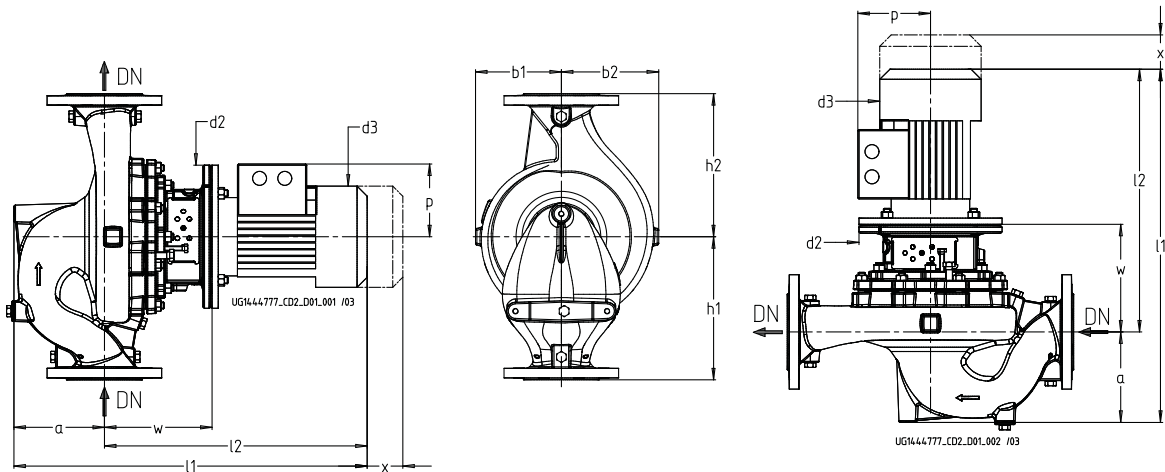

Pump set dimensions

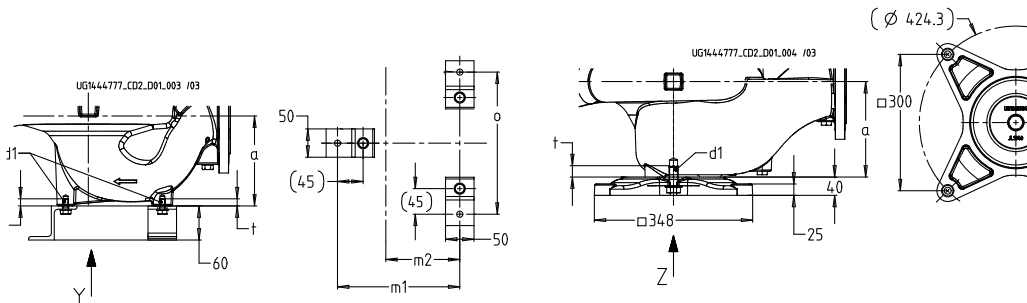

Foundation fastening dimensions

Dimensions

Size	Motor	DN <sub>14</sub>	a	~b <sub>1</sub> <sub>15</sub>	~b <sub>2</sub> <sub>15</sub>	d <sub>1</sub>	d <sub>2</sub>	d <sub>3</sub>	p	h <sub>1</sub>	h <sub>2</sub>	~l <sub>1</sub> <sub>15</sub>	~l <sub>2</sub> <sub>15</sub>	t	~x <sub>15</sub>	w	m <sub>1</sub>	m <sub>2</sub>	o
	[kW]																		
[mm]																			
032-032-160	0,25	32	87	119	131	M10	160	145	111	180	160	460	373	12,5	100	136	175	100	190
032-032-160	0,37	32	87	119	131	M10	160	145	111	180	160	460	373	12,5	100	136	175	100	190
032-032-160	0,55	32	87	119	131	M10	200	162	120	180	160	498	411	12,5	100	156	175	100	190
032-032-160	0,75	32	87	119	131	M10	200	162	120	180	160	498	411	12,5	100	156	175	100	190
032-032-160	1,1	32	87	119	131	M10	200	190	128	180	160	525	438	12,5	100	156	175	100	190
032-032-200	0,37	32	100	134	146	M10	160	145	111	250	190	473	373	12,5	100	136	175	100	190
032-032-200	0,55	32	100	134	146	M10	200	162	120	250	190	511	411	12,5	100	156	175	100	190
032-032-200	0,75	32	100	134	146	M10	200	162	120	250	190	511	411	12,5	100	156	175	100	190
032-032-200	1,1	32	100	134	146	M10	200	190	128	250	190	538	438	12,5	100	156	175	100	190
032-032-200	1,5	32	100	134	146	M10	200	190	128	250	190	564	464	12,5	100	156	175	100	190
032-032-200	2,2	32	100	134	146	M10	250	213	135	250	190	617	517	12,5	100	170	175	100	190
040-040-160	0,37	40	114	118	132	M10	160	145	111	180	160	487	373	12,5	100	136	165	90	190
040-040-160	0,55	40	114	118	132	M10	200	162	120	180	160	525	411	12,5	100	156	165	90	190
040-040-160	0,75	40	114	118	132	M10	200	162	120	180	160	525	411	12,5	100	156	165	90	190
040-040-160	1,1	40	114	118	132	M10	200	190	128	180	160	552	438	12,5	100	156	165	90	190
040-040-160	1,5	40	114	118	132	M10	200	190	128	180	160	578	464	12,5	100	156	165	90	190
040-040-250	0,75	40	104	163	173	M10	200	162	120	220	220	519	415	12,5	100	160	175	100	190
040-040-250	1,1	40	104	163	173	M10	200	190	128	220	220	546	442	12,5	100	160	175	100	190
040-040-250	1,5	40	104	163	173	M10	200	190	128	220	220	572	468	12,5	100	160	175	100	190
040-040-250	2,2	40	104	163	173	M10	250	213	135	220	220	625	521	12,5	100	174	175	100	190

14) DN = EN 1092-2, PN 16

15) For the exact motor-related dimensions refer to the general arrangement drawing.







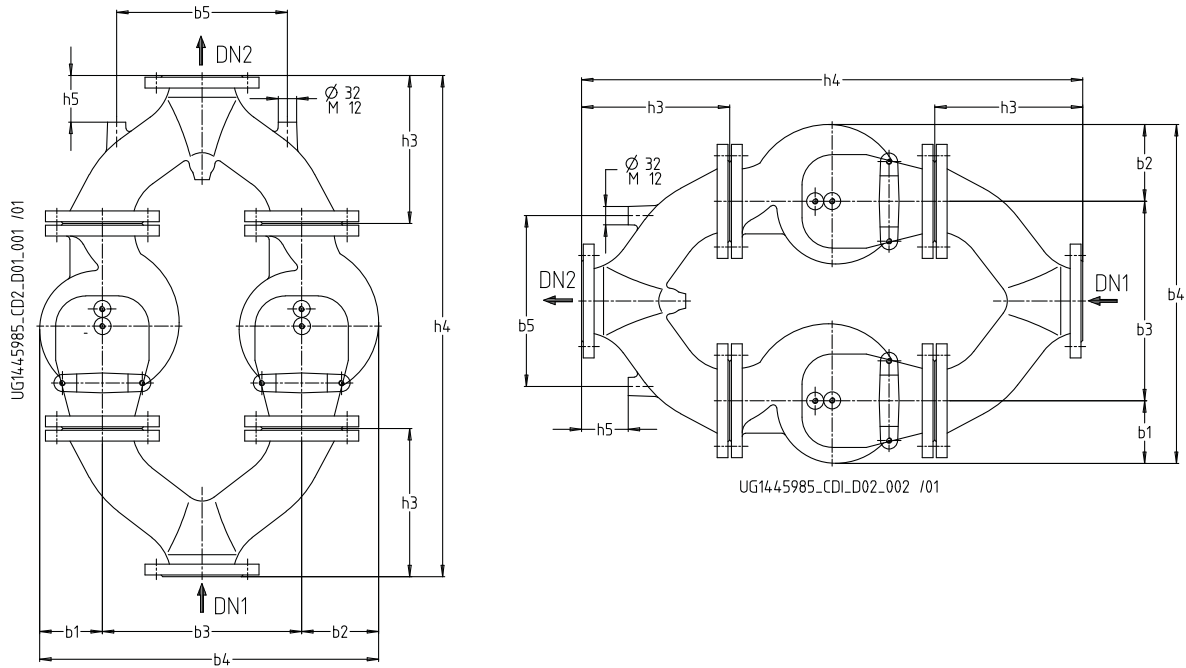

Dimensions of Y-pipes

Dimensions of Y-pipes

Size	Motor	DN <sub>1</sub> <sup>16)</sup>	b <sub>3</sub>	b <sub>4</sub>	b <sub>5</sub>	h <sub>3</sub>	h <sub>4</sub>	h <sub>5</sub>
	[kW]							
050-050-160	0,37	50	300	481	230	210	862	65
050-050-160	0,55	50	300	481	230	210	862	65
050-050-160	0,75	50	300	481	230	210	862	65
050-050-160	1,1	50	300	481	230	210	862	65
050-050-160	1,5	50	300	481	230	210	862	65
050-050-160	2,2	50	300	481	230	210	862	65
065-065-160	0,37	65	325	549	300	230	902	82
065-065-160	0,55	65	325	549	300	230	902	82
065-065-160	0,75	65	325	549	300	230	902	82
065-065-160	1,1	65	325	549	300	230	902	82
065-065-160	1,5	65	325	549	300	230	902	82
065-065-160	2,2	65	325	549	300	230	902	82
065-065-160	3,0	65	325	549	300	230	902	82
080-080-160	0,55	80	350	566	300	260	962	82
080-080-160	0,75	80	350	566	300	260	962	82
080-080-160	1,1	80	350	566	300	260	962	82
080-080-160	1,5	80	350	566	300	260	962	82
080-080-160	2,2	80	350	566	300	260	962	82
080-080-160	3,0	80	350	566	300	260	962	82
080-080-160	4,0	80	350	566	300	260	962	82
100-100-125	0,75	100	325	572	300	295	1042	85
100-100-125	1,1	100	325	572	300	295	1042	85
100-100-125	1,5	100	325	572	300	295	1042	85
100-100-125	2,2	100	325	572	300	295	1042	85
100-100-160	1,5	100	325	591	300	295	1042	85
100-100-160	2,2	100	325	591	300	295	1042	85
100-100-160	3,0	100	325	591	300	295	1042	85
100-100-160	4,0	100	325	591	300	295	1042	85
100-100-160	5,5	100	325	591	300	295	1042	85

16) DN = EN 1092-2, PN 16

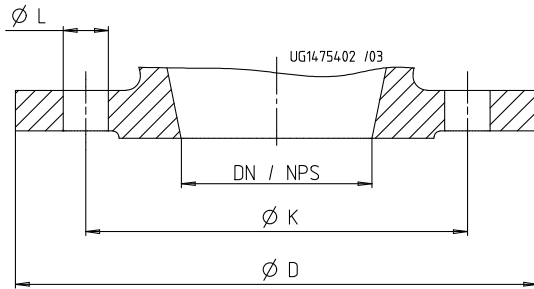
**Flange dimensions**

Flange dimensions

Flange dimensions [mm]

DN / NPS	Standard					
	EN 1092-2			ASME B 16.1		
	Material					
	G			G		
	PN 16			Class 125		
	Ø K	Ø D	Number of holes L	Ø K	Ø D	Number of holes L
32 / NPS11/4	100	140	4×Ø19	88,9	140	4×Ø15,7
40 / NPS11/2	110	150	4×Ø19	98,6	150	4×Ø15,7
50 / NPS2	125	165	4×Ø19	120,7	165	4×Ø19,1
65 / NPS21/2	145	185	4×Ø19	139,7	185	4×Ø19,1
80 / NPS3	160	200	8×Ø19	152,4	200	4×Ø19,1
100 / NPS4	180	229	8×Ø19	190,5	229	8×Ø19,1
125 / NPS5	210	254	8×Ø19	215,9	254	8×Ø22,4
150 / NPS6	240	285	8×Ø23	241,3	285	8×Ø22,4
200 / NPS8	295	343	12×Ø23	298,5	343	8×Ø22,4

**Flange design**

Flange design by materials

Material variant	Standard	Nominal size	Pressure class
G, GB, GC	EN 1092-2	DN 32 - DN 200	PN 16
	Drilled to ASME B16.1 <sup>17)</sup>	DN 32 - DN 200	Class 125

<sup>17)</sup> DN 80 machined like DN 100

### Typical installation positions

#### Horizontal installation

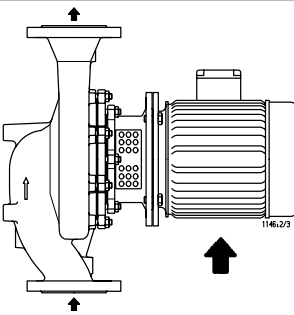
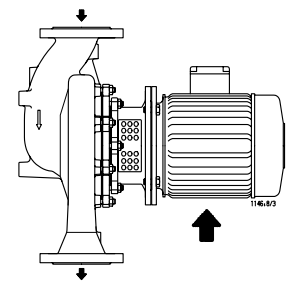
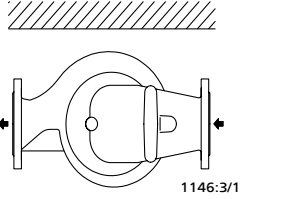
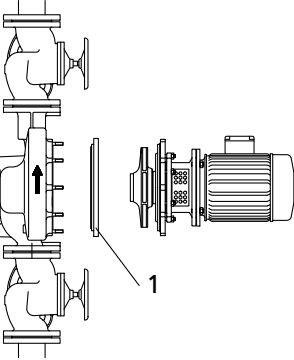
Examples	Special aspects
 <p data-bbox="151 616 375 674">Direction of flow from bottom to top</p>	<p data-bbox="456 280 837 309"><b>Direction of flow from bottom to top</b></p> <p data-bbox="456 313 1412 398">Please note: Motors of size 180 (18.5 kW) and above on pump sets with horizontal motor axis require adequate support! The foot fastening holes on the motor housing can be used for this purpose.</p>
 <p data-bbox="151 996 446 1068">Direction of flow from top to bottom</p>	<p data-bbox="456 674 837 703"><b>Direction of flow from top to bottom</b></p> <p data-bbox="456 707 1412 768">The volute casing and/or back pull-out unit must be turned by 180° so that the terminal box remains in its current position on top.</p> <p data-bbox="456 772 1412 857">Please note: Motors of size 180 (18.5 kW) and above on pump sets with horizontal motor axis require adequate support! The foot fastening holes on the motor housing can be used for this purpose.</p>
 <p data-bbox="151 1265 375 1294">Horizontal installation</p>	<p data-bbox="456 1068 1005 1097"><b>Horizontal installation (for example under the ceiling)</b></p> <p data-bbox="456 1102 1372 1162">The volute casing and/or back pull-out unit must be turned by 90° so that the terminal box remains in its current position on top.</p>
 <p data-bbox="151 1657 446 1684">Installation with blind flange</p>	<p data-bbox="456 1294 750 1323"><b>1 = Blind flange (accessories)</b></p> <p data-bbox="456 1328 1428 1388">If one of the pumps needs to be serviced, the pump chamber can be shut off by a blind flange so that the system remains operational.</p>

Vertical installation

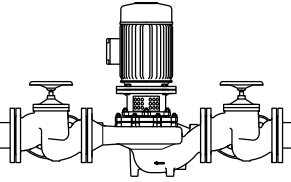
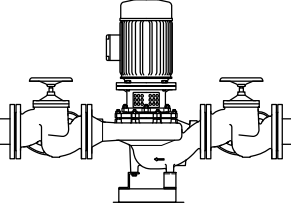
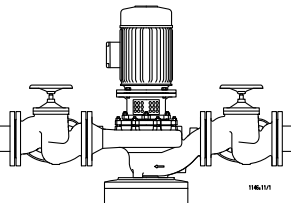
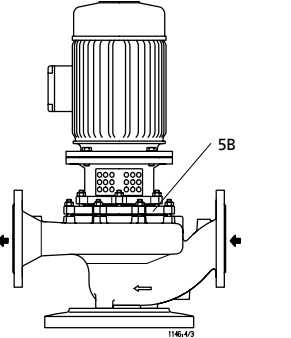
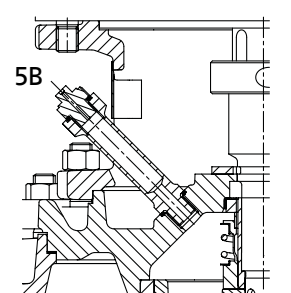
Example drawing	Particularities
 <p>Vertical installation without feet</p>	<p><b>Mounted without feet</b></p> <p>Sizes 032-032-160 to 100-100-125</p> <p>Pumps up to size 100-100-125 can be installed directly in the piping without requiring any additional supports. Always anchor the pipes in close proximity to the pump in this case.</p>
 <p>Vertical installation with angle feet</p>	<p><b>Mounted on 3 angle feet (St 37, accessory)</b></p> <p>Sizes 032-032-160 to 100-100-125</p>
 <p>Vertical installation with pump foot</p>	<p><b>Mounted on pump foot (grey cast iron, accessory)</b></p> <p>Sizes 100-100-160 to 200-200-315</p>
 <p>Vertical installation – Information about vent valve</p>	<p>Provide a vent valve to prevent dry running of the mechanical seal. (Pumps which have been ordered for vertical installation are supplied with a vent valve.) For vertical installation with the motor on top, use connection 5B for venting.</p>
 <p>Vent, mechanical seal chamber</p>	<p>The mechanical seal chamber can be vented with vent valve 5B.</p>

**Accessories**
**Pump accessories**

Overview of pump accessories

Component	Connection		Mat. No.	[kg]
Pump foot required for vertical installation	Etaline 032-032-160 to 100-100-125 <sup>18)</sup>		47077960	1.5
	Etaline 100-100-160 to 200-200-315 <sup>19)</sup>		01614068	12.4
Vent valve 5B <sup>20)</sup> for vertical installation				
Blind flange comprising blind flange and gasket	Etaline 032/040/050/065/080/100-160, 100-125		01621012	6.7
	Etaline 032/080/100/125/150-200, 125-160		01621013	12.4
	Etaline 040/050/065/080/100/125/150/200-250		01621014	14.7
	Etaline 200-315		01621015	22.2
Y-pipes for dual-pump stations, grey cast iron, with hexagon head bolts, nuts and gaskets; flanges drilled to DIN 2501 PN 16	DN 50	Suction side	40000689	13.5
	DN 50	Discharge side	40000680	16
	DN 65	Suction side	40000690	18.3
	DN 65	Discharge side	40000681	20.4
	DN 80	Suction side	48936065	25
	DN 80	Discharge side	48936202	28.1
	DN 100	Suction side	40000692	31
	DN 100	Discharge side	40000440	34



<sup>18)</sup> 3 pump feet with bolts

<sup>19)</sup> One pump foot with bolt

<sup>20)</sup> Can only be processed via KSB EasySelect (configurable range)

**Electrical accessories**

Further electrical accessories

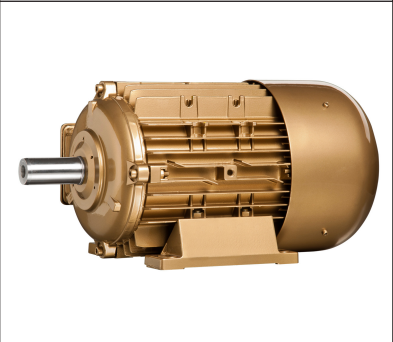
Component	Description
	<p><b>PumpMeter</b> intelligent pressure transmitter</p> <p>The PumpMeter device is an intelligent pressure transmitter for pumps, with on-site display of measured values and operating data. The device comprises two pressure sensors and a display unit. It records the load profile of the pump in order to indicate any potential for optimising energy efficiency and availability. PumpMeter is supplied completely assembled and parameterised for the pump it is used with. It is ready for operation as soon as the M12 plug connector is plugged in.</p>
 <p>PumpDrive 2 / PumpDrive 2 Eco</p>	<p><b>PumpDrive</b> self-cooling frequency inverter</p> <p>PumpDrive is a modular, self-cooling frequency inverter which enables continuously variable speed control of asynchronous motors and synchronous reluctance motors by means of analog standard signals or the control panel.</p> <p>The parts of the PumpDrive housing which are in contact with the atmosphere are free from paint-wetting impairment substances.</p> <p>Mounting options:</p> <ul style="list-style-type: none"> <li>▪ Motor-mounted model</li> <li>▪ Wall-mounted model</li> <li>▪ Cabinet-mounted model</li> </ul>
	<p><b>KSB SuPremE motor</b></p> <p>Magnetless synchronous reluctance motor of efficiency class IE4 in compliance with IEC CD 60034-30 Ed. 2, 05-2011 for operation with a KSB PumpDrive variable speed control system, no rotor position sensors needed</p>

General assembly drawings

Variant with bolted casing cover

[ Supplied in packaging units only

This view applies to the following pump sizes:

032-032-200 040-040-250 050-050-250 065-065-250 080-080-200 100-100-250 125-125-250 150-150-250 200-200-250  
080-080-250 200-200-315

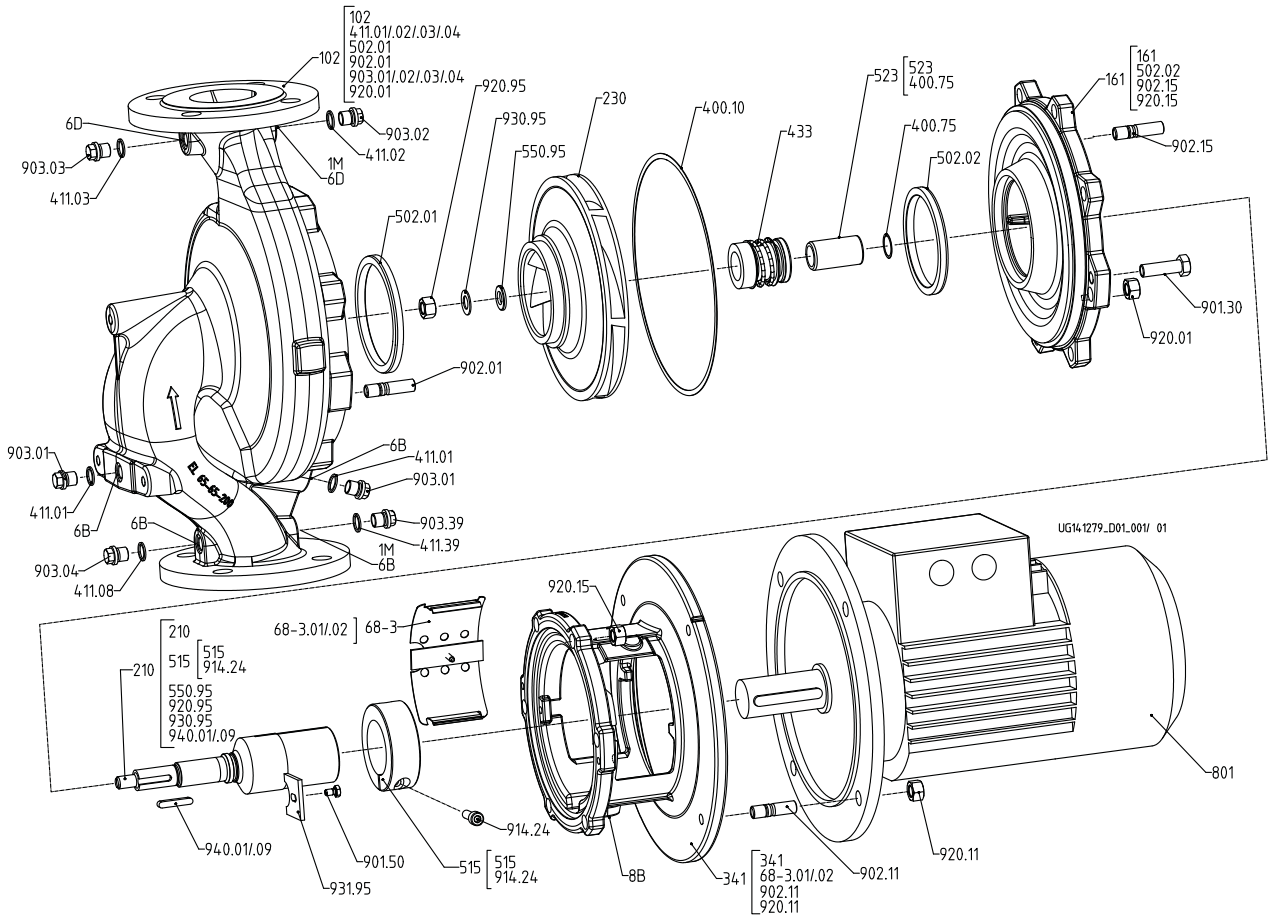

Model with bolted casing cover

List of components

Part No.	Description	Part No.	Description
102	Volute casing	901.30.50	Hexagon head bolt
161	Casing cover	902.01.11/.15	Stud
210	Shaft	903.01/.02/.03/.04/.08/.39	Screw plug
230	Impeller	914.24	Hexagon socket head cap screw
341	Drive lantern	920.01/.11/.15/.95	Hexagon nut
400.10/.75	Gasket	930.95	Safety device
411.01/.02/.03/.04/.08/.39	O-ring	931.95	Lock washer
433	Mechanical seal	940.01/.09	Key
502.01/ 02	Casing wear ring		
515	Taper lock ring	<b>Auxiliary connections</b>	
523	Shaft sleeve	1M	Pressure gauge
550.95	Disc <sup>21)</sup>	6B	Fluid drain

21) For shaft unit 25 only



Part No.	Description	Part No.	Description
68-3.01/02	Cover plate	6D	Fluid priming and venting
801	Flanged motor	8B	Leakage drain

**Variant with clamped casing cover**

[ Supplied in packaging units only

This view applies to the following pump sizes:

- |           |           |           |           |           |             |             |             |
|-----------|-----------|-----------|-----------|-----------|-------------|-------------|-------------|
| 32-32-160 | 40-40-160 | 50-50-160 | 65-65-160 | 80-80-160 | 100-100-125 | 125-125-160 | 150-150-200 |
|           |           |           |           |           | 100-100-160 | 125-125-200 |             |
|           |           |           |           |           | 100-100-200 |             |             |

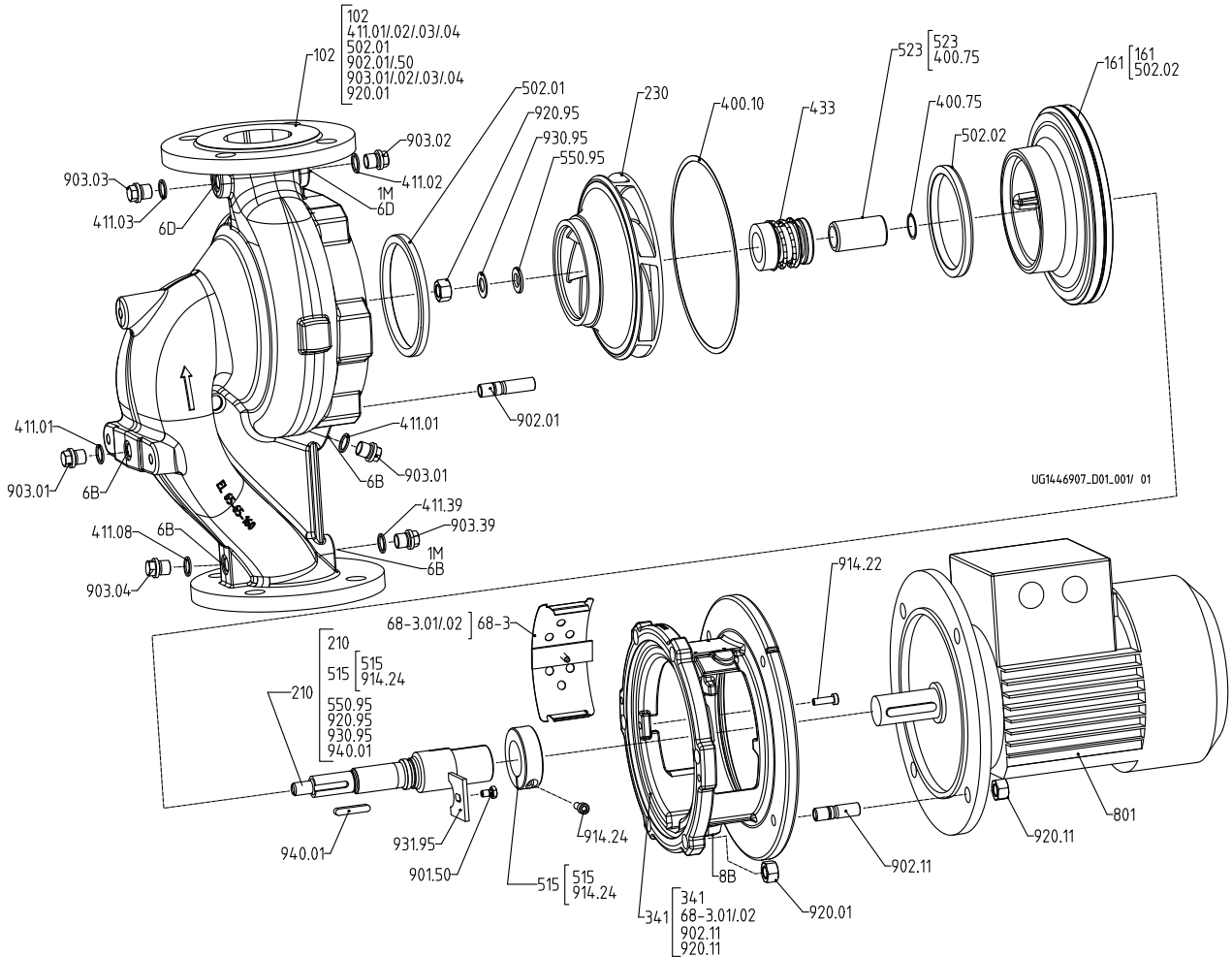

Pump set with single mechanical seal and clamped casing cover

List of components

Part No.	Description	Part No.	Description
102	Volute casing	901.50	Hexagon head bolt
161	Casing cover	902.01/11/50	Stud
210	Shaft	903.01/02/03/04/08/39	Screw plug
230	Impeller	914.22/24	Hexagon socket head cap screw
341	Drive lantern	920.01/11/95	Hexagon nut
400.10/75	Gasket	930.95	Safety device
411.01/02/03/04/08/39	O-ring	931.95	Lock washer
433	Mechanical seal	940.01	Key
502.01/02	Casing wear ring		
515	Taper lock ring	<b>Auxiliary connections</b>	
523	Shaft sleeve	1M	Pressure gauge
550.95	Disc <sup>22)</sup>	6B	Fluid drain

<sup>22)</sup> For shaft unit 25 only

Part No.	Description	Part No.	Description
68-3.01/02	Cover plate	6D	Fluid priming and venting
801	Flanged motor	8B	Leakage drain

### Variant with pump feet for vertical installation

This view applies to the following pump sizes:

032-032-160	040-040-160	050-050-160	065-065-160	080-080-160	100-100-125
032-032-200	040-040-250	050-050-250	065-065-250	080-080-200	
				080-080-250	

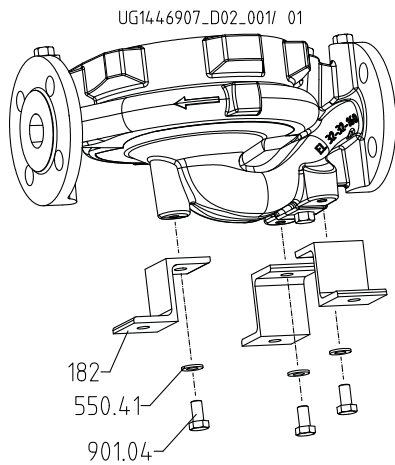

### Vertical installation with angle feet

This view applies to the following pump sizes:

100-100-160	125-125-160	150-150-200	200-200-250
100-100-200	125-125-200	150-150-250	200-200-315
100-100-250	125-125-250		

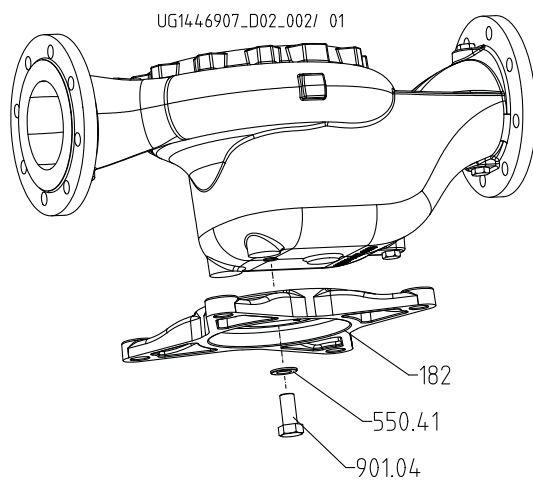

### Vertical installation with pump foot

List of components

Part No.	Description
182	Foot
550.41	Disc
901.04	Hexagon head bolt

### Detailed designation

Designation example

Position																																												
1	2	3	4	5	6	7	8	9	10	11	12	13	14	15	16	17	18	19	20	21	22	23	24	25	26	27	28	29	30	31	32	33	34	35	36	37	38	39	40	41	42	43	44	
E	T	L	-	0	3	2	-	0	3	2	-	1	6	0	-	G	G	-	A	A	1	1	D	2	5	0	0	3	0	4	e	x	B	S	I	E	I	E	3	P	D	2	E	M
See name plate and data sheet																							See data sheet																					

Designation key

Position	Code	Description
1-4	Pump type	
	ETL-	Etaline
	ETLY	Etaline SYT
5-16	Size	
	032	Nominal suction nozzle diameter [mm]
	032	Nominal discharge nozzle diameter [mm]
	160	Nominal impeller diameter [mm]
17	Pump casing material	
	G	JL 1040/A48CL35
	S	EN-GJS-400-15
18	Impeller material	
	G	JL 1040/A48CL35
	C	1.4408/A743CF8M
	B	CC480K-GS/B30 C90700
19	Design	
	-	Standard
	X	Special design BT3D, BT3
20	Casing cover	
	A	Conical seal chamber
21	Type of seal	
	B	Dead-end (Etaline SYT)
	V	Conical seal chamber with vent
	A	Conical seal chamber
22-23	Seal code	
	06	U3BEGG (shaft units 25, 35)
	07	Q1Q1EGG
	08	AQ1VGG
	09	U3U3VGG
	10	Q1Q1X4GG
	11	BQ1EGG
22	AQ1EGG (shaft unit 55)	
24	Scope of supply	
	A	Pump only (Fig. 0)
	D	Pump, baseplate, coupling, coupling guard, motor
25	Shaft unit	
	2	Shaft unit 25
	3	Shaft unit 35
	5	Shaft unit 55
26-29	Motor rating (basis: 50 Hz)	
	0002	0,25 KW
	0003	0,37 KW
	0005	0,55 KW
	0007	0,75 KW
	0011	1,1 KW
	0015	1,5 KW
	0022	2,2 KW
	0030	3,0 KW
	0040	4,0 KW
	0055	5,5 KW
	0075	7,5 KW
	0110	11,0 KW
	0150	15,0 KW
0185	18,5 KW	
0220	22,0 KW	
0300	30,0 KW	

Position	Code	Description
	0370	37,0 KW
	0450	45,0 KW
	0550	55,0 KW
30	Number of poles	
	2	2 poles
	4	4 poles
31-32	Explosion protection	
	Ex	Explosion-proof motor
	--	Without explosion-proof motor
33	Product generation	
	B	Product generation Etaline / Etaline SYT GP
34-36	Motor manufacturer	
	KSB	KSB
	SIE	Siemens
	LOH	Loher
	HAL	Halter
37-39	Efficiency class	
	IE1	IE1
	IE2	IE2
	IE3	IE3
	IE4	IE4
40-43	PumpDrive	
	PDB	PumpDrive 1st generation, Basic
	PDA	PumpDrive 1st generation, Advanced
	PD2	PumpDrive 2nd generation
	PD2E	PumpDrive 2nd generation, Eco
44	PumpMeter	
	M	With PumpMeter





**KSB Aktiengesellschaft**

67225 Frankenthal • Johann-Klein-Str. 9 • 67227 Frankenthal (Germany)

Tel. +49 6233 86-0 • Fax +49 6233 86-3401

[www.ksb.com](http://www.ksb.com)

DYSTRYBUTOR

Valmark Sp. z o.o.

tel: (22) 868 58 58

mail: [biuro@valmark.pl](mailto:biuro@valmark.pl)

21.07.2016

1159.5/03-EN